

BASIC CIRCUIT CONCEPTS

A properly designed interface circuit plays a key role in the optimization of piezo film sensors. The applications of piezo film span from toys to military sensors and interfacing to electronics is highly application dependent. In many cases, piezo film can be directly connected to electronic circuits without special interface considerations. However, for those cases where an interface circuit is required, the following 3 steps are recommended:

1. Consider the frequency range and signal amplitude requirements over the desired dynamic range.
2. Choose a proper load resistance to assure the low end operating frequency and to minimize signal loss due to the loading effect.
3. Select a buffer circuit if the signal level is small. If a high value load resistance is needed (such as 22M Ω or higher value), a low leakage high impedance buffer amplifier is recommended. JFET's or CMOS operational amplifiers are commercially available for a buffer.

Simplified Equivalent Circuits

The first step in an interface circuit design is to understand the piezo film characteristics as part of an electrical equivalent circuit. Figure 1 shows a simplified equivalent circuit of piezo film. It consists of a series capacitance with a voltage source. The series capacitance C_f represents piezo film capacitance which is proportional to the film permittivity and area and inversely proportional to film thickness. The voltage source amplitude is equal to the open circuit voltage of piezo film and varies from microvolts to 100's of volts, depending on the excitation magnitude. This simplified equivalent circuit is suitable for most applications but is of limited value at very high frequencies such as that used in ultrasound transducers.

Figure 1. Equivalent circuit of piezo film

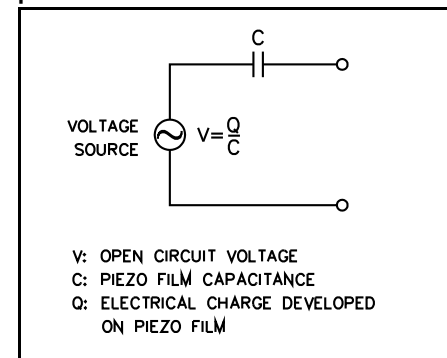
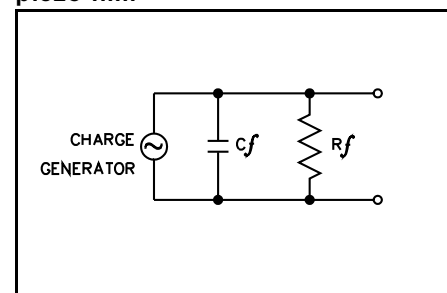

Figure 2 shows an equivalent circuit as a charge generator. This equivalent circuit has film capacitance C_f , and internal film resistance R_f . The induced charge Q is linearly proportional to the applied force as described earlier. The capacitance C_f is proportional to the surface area of film and is inversely proportional to the film thickness. In low frequency applications, the internal film resistance R_f is very high and can be ignored. The open circuit output voltage can be found from the film capacitance; i.e., $V=Q/C_f$.

Figure 2. Equivalent circuit for piezo film



Input Resistance

The most critical part of an interface circuit is the input

resistance. The input resistance affects low frequency measurement capability as well as signal amplitude. This is called the "loading effect".

Piezo film capacitance can be regarded as an equivalent source impedance. It is important to note that this source impedance increases with decreasing film capacitance and decreasing frequency of operation. This source impedance combined with the input resistance produces a voltage divider. As the ratio of input resistance to source impedance is decreased, the overall output voltage is reduced. Therefore, choosing a proper input resistance for the electronic interface is critical in minimizing the loading effect.

Time Constant

In addition to input resistance, the input capacitance of an interface circuit can also affect the output. Figure 3 shows the equivalent circuit of film with input resistance R_i and input capacitance C_i . A typical time domain response of piezo film is shown in Figure 4. The charge developed on the film due to an applied force decays with a time constant which is defined by $R_i(C_f + C_i)$.

This time constant represents the time required for a signal to decay to 70.7% (-3dB) of its original amplitude. The smaller the time constant, the quicker the signal decays. Because of this finite time constant, piezo film is suitable for dynamic measurements rather than static measurement (0.001 Hz minimum).

If a long time constant is desired, a high input resistance and film capacitance can be used. It should be understood, however, that a high input resistance can also produce higher noise, requiring compensation through shielding, etc.

Frequency Response

Another important aspect of the time constant can be seen in the frequency response of the equivalent circuit. The circuit exhibits an RC high-pass filter characteristic as shown in Figure 5. In this figure, the vertical axis implies the ratio of observable output signal to the developed signal (open circuit voltage of the piezo film). Zero dB implies no loss of signal. The cutoff frequency (3 dB down) is inversely proportional to the time constant. When a piezo film sensor is operated below this cut-off frequency, the output signal is significantly reduced. For a low frequency measurement, an

Figure 3. Equivalent circuit of piezo film with input resistance of electronic interface

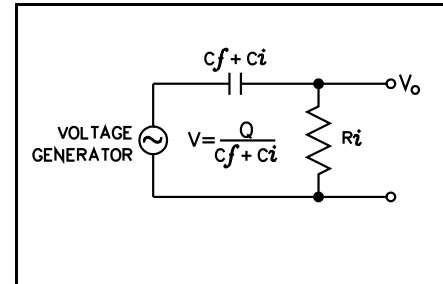

Figure 4. Time response of piezo film

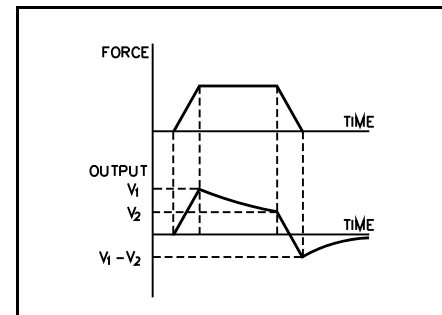
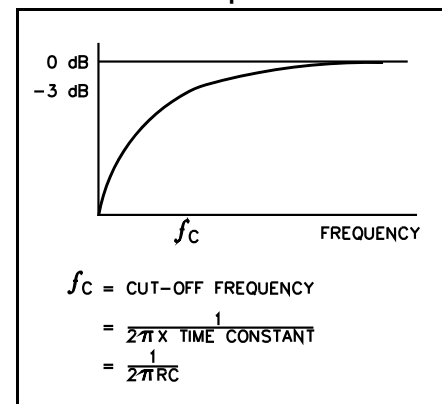

Figure 5. High pass filter characteristic of piezo film



input resistance needs to be high enough so that the cut-off frequency is well below the desired operating frequency. This consequence can be verified from consideration of the time constant as well as the loading effect.

As an example, the frequency response of a shielded piezo film sensor (model SDT1) is shown in Figure 6. In this example, the SDT is interfaced with a circuit which contains a 10MΩ load resistor and an FET. The capacitance of the piezo film is 2.4 nF. With 10MΩ load resistance, the time constant becomes 24 msec and thus, the cut-off frequency is 6.6 Hz. For comparison, the cut-off frequency can be reduced to 0.66 Hz if a 100MΩ resistor is used instead of the 10MΩ resistor. This sensor component can be used for any application operating above the cut-off frequency determined by the resistance value.

In applications where the electronic circuit cannot be placed near the sensor, a buffer circuit is recommended close to the sensor. The buffer circuit converts the high output impedance of the piezo film element into a low output impedance and thus minimizes the signal loss and noise through the cable. For large size (i.e., high capacitance) piezo film sensors a buffer may not be required, even with small signals and long cables.

When a high piezo film output impedance is required, a low-leakage, high impedance buffer is necessary. For example, infrared motion sensor and accelerometer applications require up to 50GΩ of input resistance to obtain a very low frequency response. For such cases, the input impedance of the buffer must be much higher than the output resistance of the piezo film in order to maintain the low frequency response. In addition, minimum leakage current of the buffer is critical in order to maximize the measurement accuracy. Some examples of low leakage buffer electronics include: JFET - 4117 (Siliconix, Sprague); Operational amplifiers — LMC660, LF353 (National Semiconductor), OP80 (PMI), and 2201 (Texas Instruments).

Figure 7 shows unity gain buffer circuit examples for general applications.

Operational amplifiers offer a great deal of versatility as both buffers and amplifiers. They can be used as either charge-mode or voltage-mode amplifiers. Figure 8 shows basic charge and voltage amplifier configurations. The

Figure 6. Frequency response of SDT1

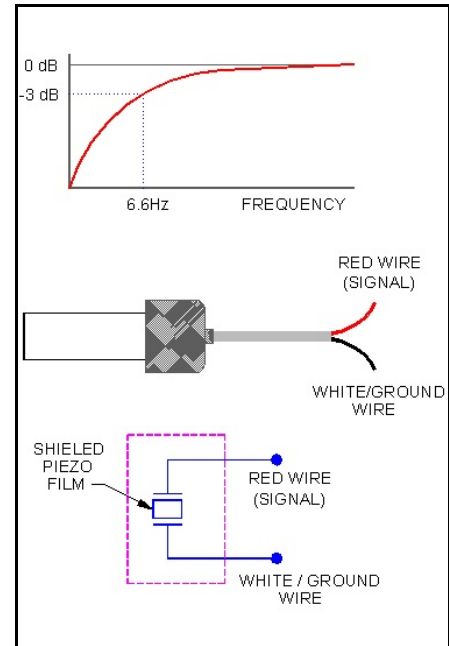
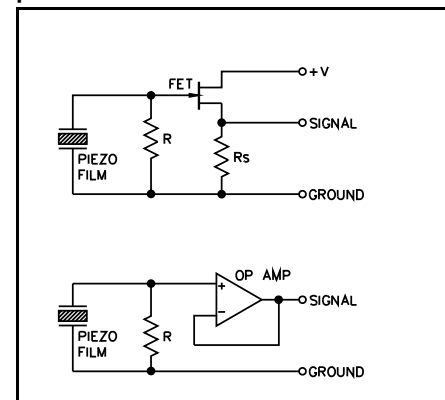

Figure 7. Unity gain buffer for piezo film sensors



voltage output of the charge amplifier is determined by Q/C_f . Q is the charge developed on the piezo film and C_f is the feedback capacitance of the charge amplifier.

The output voltage of the charge amplifier depends on the feedback capacitance, not the input capacitance. This indicates that the output voltage of a charge amplifier is independent of the cable capacitance. The major advantage of a charge amplifier can be realized when a long cable is used between a piezo film sensor and electronics. In addition, it also minimizes charge leakage through the stray capacitance around the sensor. Otherwise, simple voltage amplifiers are sufficient for most applications. Included in Figure 7 is a typical non-inverting voltage amplifier.

The advantage of a voltage amplifier can be seen when ambient temperature is considered. The voltage sensitivity (g-constant) variation over temperature is smaller than the charge sensitivity (d-constant) variation. Consequently, voltage amplifiers with piezo film exhibit less temperature dependence. In Figure 8, the time constants for the charge amplifier and voltage amplifier are determined by RC_f and RC respectively.

As a design example, a traffic sensor interface is described. Because of its flexibility, piezo cable is an ideal sensor material for traffic measurement applications. MEAS's BL traffic sensor is constructed with a piezo cable sheathed in a compressed brass tube, with a variety of signal cable lengths tailored to the installation requirements. The BL is available in sensing lengths of more than 3 meters. In this specific example, the BL sensor is 2 meters long. This electrically shielded sensor has 100 feet of coax cable. The electrical specifications of this sensor include:

Capacitance = 9.5 nF (including piezo cable and signal cable capacitances)
Output = 500mV (for a wheel load of 800 pounds at 55mph and 70°F)
Signal : Noise = 10:1

The basic requirements of an interface circuit are:

Low end frequency = 1.6 Hz
Circuit output = Digital pulse count

An interface circuit to meet these requirements is shown in Figure 9. This circuit works as a comparator. A 10MΩ input

Figure 8. Typical amplifiers for piezo film sensors

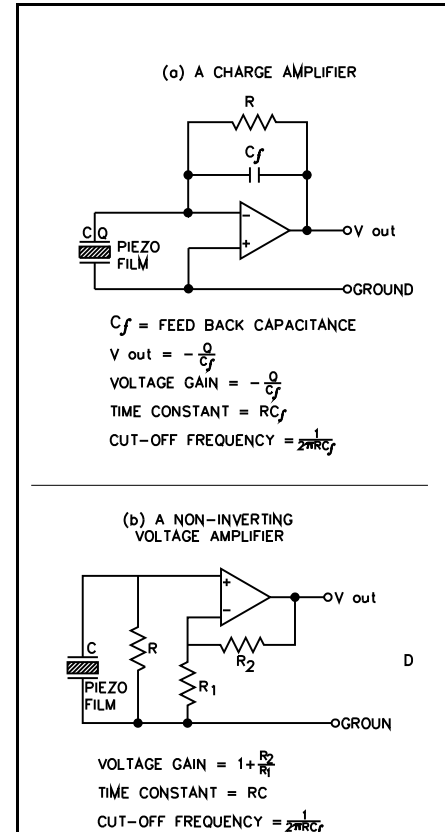
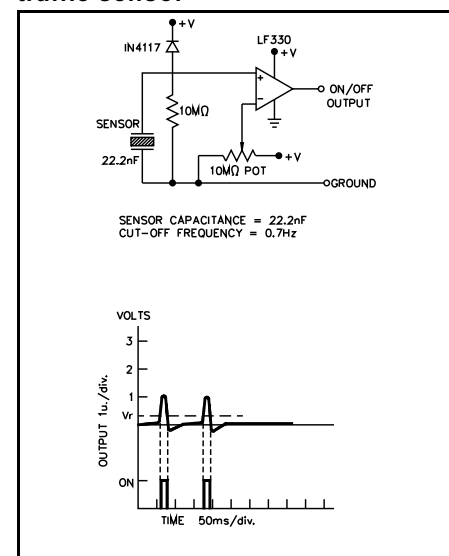

Figure 9. An interface circuit of a traffic sensor



resistance is chosen in order to reduce the cut-off frequency to about 1 Hz. The actual cut-off frequency with this resistor can be calculated as 1.6 Hz. A 10M Ω potentiometer is used to adjust the threshold voltage, V and the diode is included to protect the electronics from high voltage damage. Typical piezo film and interface circuit output signals from a passenger car at 55 mph are shown in Figure 9.

Signal Conditioning

Because piezo film is both piezoelectric and pyroelectric, some provision must be made to eliminate—or at least reduce—the effect of unwanted signals. The primary principles of signal conditioning include:

- Filtering—Electrical filters designed to give the desired band-pass and band-rejection characteristics.
- Averaging—If the desired signal exhibits periodicity, while the undesired signal is random, signal averaging can increase the signal-to-noise ratio.
- Common Mode Rejection—By wiring two equal areas of a piezo film electrode out-of-phase, unwanted common-mode signals can be made to cancel.

Basic Switch Circuitry

A variety of circuits are available to electronically interface with piezo film including field effect transistors (FETs), operational amplifiers (Op Amps), and low-current digital logic (CMOS).

FETs lend themselves to applications of small size since they are readily available in surface mount technology. Important characteristics to consider when using FETs are switching frequency, piezo film capacitance, leakage current of the FET in the off-state, input bias resistance, and shielding from electromagnetic interference (EMI).

Figures 10 and 11 show typical FET circuit configurations for a piezo film switch. Figure 10, the common drain or source follower, applies well in applications where simple buffering is important. Here, the circuit voltage gain is approximately one.

The common source circuit in Figure 11 is suitable for low frequency applications where voltage gain is required. The gain is determined by resistances R_D and R_S . As the gain increases, frequency bandwidth decreases by a factor of one decade per 20 dB of gain.

Operational amplifiers offer a great deal of versatility for piezo film switch applications. Adaptation to a particular application is often as simple as making a few wiring

Figure 10. High frequency, low gain FET circuit interface

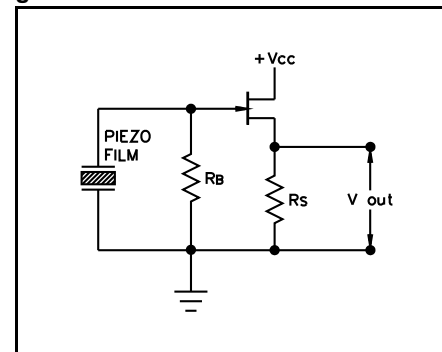
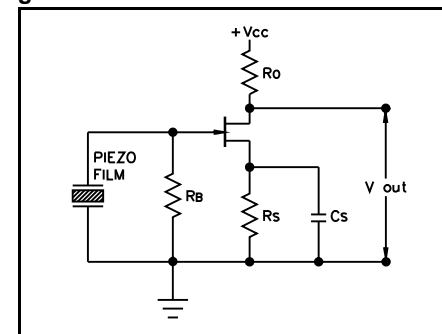

Figure 11. Low frequency, high gain FET circuit interface



changes. Important op amp circuit characteristics include input bias resistance, film switch capacitance, and EMI shielding.

The op amp circuit of Figure 12, a charge amplifier, suits applications where a detected vibration actuates the switch. It also works well in small signal applications. A charge amplifier eliminates the effects of the time constants of both the piezo film and connecting cable. The charge amplifier is a current operated circuit with zero input impedance, which results in no voltage being generated across the film. The charge amplifier quickly absorbs charges developed by the film. With no charge left on its electrodes, the film exhibits no time constant. The capacitance of the film and connecting cable have no adverse effect on the circuit's transfer function. Thus tolerances on film size and cable length need not be exceptionally tight. The charge is transferred from the film to the capacitor in the amplifier's feedback loop, which determines the output voltage: $V = Q/C_f$.

The charge amplifier requires an op amp having a high input resistance and low bias current. A high input resistance avoids bleed-off of the charge on the feedback capacitor, and low bias current prevents the feedback capacitor from charging and discharging at excessive rates. The layout of the charge amplifier circuit is critical. The op-amp casing must be well grounded and the inputs should be guarded and connected to the same ground as the casing.

A layout with guarded inputs is shown in Figure 13. Also, to prevent leakage noise from being amplified by the op-amp, the input cable should be terminated using a well-insulated stand-off connector.

Even with the above precautions, it is likely that the output voltage will drift. To compensate for drift, a reset switch is generally designed into the circuit to manually reset the output to zero at intervals. One technique is to place a reed switch in series with a resistor, which is in parallel with the feedback capacitor C_f . Activating the reed switch closes the switch, discharging the voltage stored in the feedback capacitor.

Another method is to use a MOSFET device in which the maximum output voltage and off-gate voltage determine the minimum gate voltage of the FET. In practice, a supply voltage greater than the amplifier voltage is applied to the gate of the MOSFET, thereby lowering its drain/source resistance and creating a current path for discharge of the feedback capacitor.

Figure 12. Op Amp Interface circuit acting as a charge amplifier

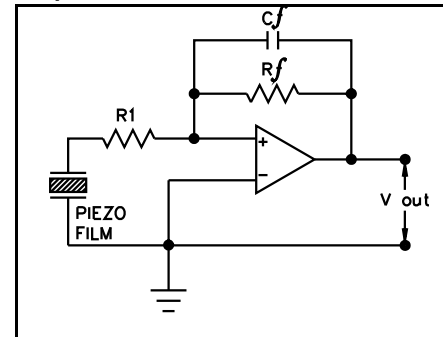

Figure 13. Layout for guarding inputs

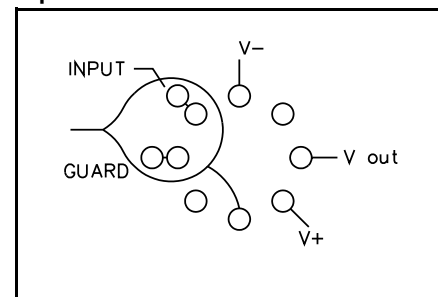
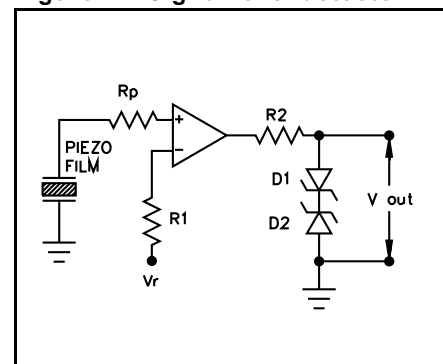

Figure 14. Signal level detector



The third alternative is to place a bleed resistor across the feedback. This resistor creates a time constant ($C_f R_f$), which is independent of the film capacitance and can be accurately controlled.

The signal level detector of Figure 14 fits applications where large signal-to-noise ratios are desirable. This circuit is perfect for detecting an impact among low-level vibrations. For situations where signal to noise ratios are low and where impacts or pressures must be discerned from background vibration, the differential amplifier circuit of Figure 15 is appropriate. This circuit consists of two sensors driving a differential amplifier.

This configuration uses a common-mode rejection concept. The two switches are mechanically coupled to cancel unwanted vibrations that stimulate both. An input or pressure on one switch but not the other, will produce an output.

CMOS logic offers a low-cost way to interface with piezo film. As mentioned earlier, low-power circuits implemented with CMOS technology are ideally suited to piezo film switches. CMOS applications for piezo film are generally for low frequency operation. Other characteristics to consider include device input leakage current and input impedance, input bias resistance, and the effect of EMI. A CMOS circuit can be used, for example, in applications to sense a single impact or a single pressure.

The D-Flip Flop in Figure 16 indicates the presence of either the impact or pressure to set off an audible alarm. The circuit in Figure 17, senses multiple impacts or pressures for counting applications.

Many different CMOS circuit configurations are possible to interface with piezo film. Common to all of them is an input bias resistor in parallel with the piezo film, and an input resistor in series with the film. The bias resistor handles leakage current and the series resistor limits current to protect against electrostatic discharge.

Figure 15. Differential Op Amp interface circuit

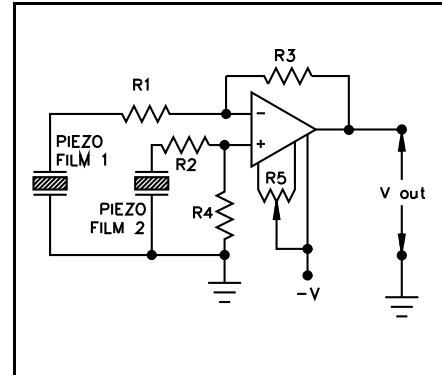

Figure 16. CMOS circuit for detecting a single impact

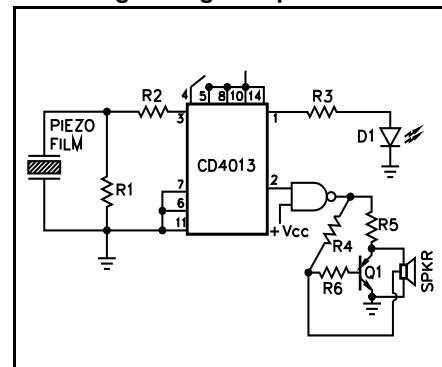
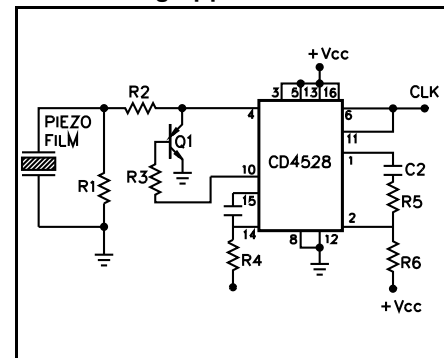

Figure 17. CMOS interface circuit for counting applications



DEALER / REVENDEDOR

Brazil and South America / Brasil e América do Sul



Address / Endereço:

Rua Sete de Setembro, 2656
13560-181 - São Carlos - SP
Brazil / Brasil

Phone / Telefone:

+55 (16) 3371-0112
+55 (16) 3372-7800

Internet:

www.metrolog.net
metrolog@metrolog.net

www.metrolog.net