

Operation Manual

LDM-1000

LVDT/RVDT Signal Conditioning Module



LDM-1000 LVDT/RVDT Signal Conditioning Module

Table of Contents

1	Introduction	3
2	Product Specifications	3
3	Product Description	4
4	Initial Setup Procedure	4
4.1	Supply Voltage	5
4.2	Internal Switches	6
4.3	Oscillator Frequency:	6
4.4	Oscillator Mode	7
4.5	Oscillator Drive Capability	7
5	Setting the Amplifier Gain	8
6	Dimensions and Wiring Terminals	9
7	Connection Diagrams	10
8	Calibration Procedure	11
9	Additional Information	12

LDM-1000 LVDT/RVDT Signal Conditioning Module

1 Introduction

The LDM-1000 is an extremely versatile LVDT/RVDT (Linear or Rotary Variable Differential Transformer) signal conditioning module. The module supplies an AC sine wave excitation to the LVDT or RVDT, and demodulates, filters, and amplifies the output. It is the perfect choice for industrial applications requiring the DIN standard rail mount.

2 Product Specifications

For complete specifications and ordering information, please refer to the datasheet at:

http://www.meas-spec.com/product/t_product.aspx?id=2588

ELECTRICAL SPECIFICATIONS	
Supply voltage	18 to 30VDC or 10 to 18VDC (<i>jumper selectable, 18 to 30VDC as shipped</i>)
Supply current	65mA maximum
Output types and ranges	±5VDC, 0 to 5VDC, 0 to 10VDC, and 4~20mA (<i>DIP switch selectable, ±5VDC as shipped</i>)
Temp. coefficient of output	±0.02% of FSO per °F [±0.036% of FSO per °C] over the operating temperature range
Voltage output noise/ripple	5mV RMS maximum
Current output noise/ripple	25µA RMS maximum
Current loop resistance	700Ω maximum (<i>with 18 to 30VDC supply voltage</i>)
Frequency response	250 or 1000Hz @ -3 dB (<i>3-pole Butterworth, DIP switch selectable, 250Hz as shipped</i>)
Non-linearity	±0.02% of FSO
Input sensitivity range	0.05 to 2.50 VRMS
Transducer excitation	
Voltage	1 or 3 VRMS (<i>DIP switch selectable; 3VRMS as shipped, with 18 to 30VDC supply voltage only</i>)
Current	25mA RMS
Frequency	2.5, 5 or 10kHz (<i>DIP switch selectable, 2.5kHz as shipped</i>)
Transducer requirements	
Transducer type	LVDT or RVDT with 4, 5 or 6 electrical connections
LVDT/RVDT input impedance	50Ω minimum @ 1 VRMS excitation ; 150Ω minimum @ 3 VRMS
LVDT/RVDT full scale output	0.05 to 2.50 VRMS

ENVIRONMENTAL AND MECHANICAL SPECIFICATIONS	
Operating temperature range	-13°F to +185°F [-25°C to 85°C]
Storage temperature range	-67°F to +257°F [-55°C to 125°C]
Mounting	Standard DIN-3 rail mount
Size	3.90 [99.0] high x 0.89 [22.5] wide x 4.51 [114.5] Deep
Wire terminal size	24 to 12 AWG [0.2 to 2.5mm]
IEC 60529 rating	IP60

Notes: All values are nominal unless otherwise noted; dimensions are in inch [mm]

FSO (Full Scale Output) is the largest absolute value of the outputs measured at the range ends.

LDM-1000 LVDT/RVDT Signal Conditioning Module

3 Product Description

DIP switches are provided to allow selection of three transducer excitation frequencies (2.5, 5 and 10 kHz), two signal bandwidths (250 or 1,000 Hertz), and two excitation voltages (1 or 3 Volts RMS). Switches are also provided to select seven coarse gain ranges, three DC output voltage ranges, two offsets, and master/slave operation. The 4 to 20mA output will operate regardless of the DC output voltage dip switch settings.

Three multi-turn potentiometers located on the front panel allow precise gain (SPAN), offset (ZERO) and phase shift (PHASE) adjustments.

An internal jumper allows changing the input voltage range from 18~30 VDC to 10~18 VDC.

The LDM-1000 is designed to be mounted to a standard number 3 DIN rail. Input/output connections are made through plug-in screw terminal barrier strips. These plug-in strips are keyed to prevent improper connections in the unlikely event that the LDM-1000 should require field replacement.

The next few pages will take you, step by step, through the simple set-up and calibration process. This device may be set-up for several different full scale analog outputs; some of the potential configurations are listed below:

- ± 5 VDC output
- 0 to 5 VDC output
- 0 to 10 VDC output
- 4 to 20mA DC output
- Standalone and Master/Slave operation

4 Initial Setup Procedure

To properly configure the LDM-1000 for the LVDT or RVDT you are using, you must access the internal dip switches. To open the housing, depress the two latches with a screwdriver (see photos below); the housing will spring open. You can slide the front panel and PC board assembly forward approximately 1.6 inch (4cm) to access the dip switches and input voltage jumper. A spring stop prevents the PCB from being removed completely.

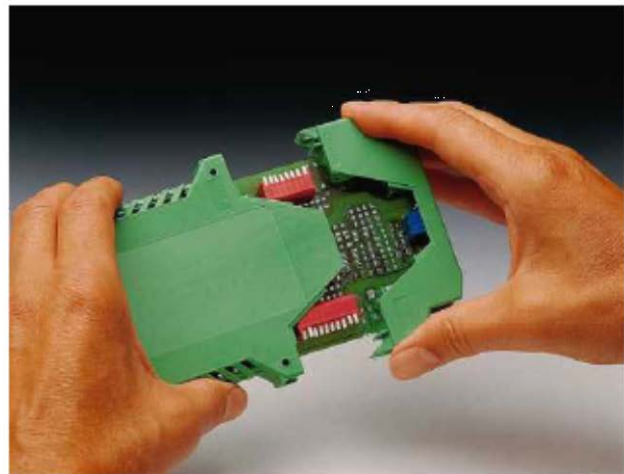
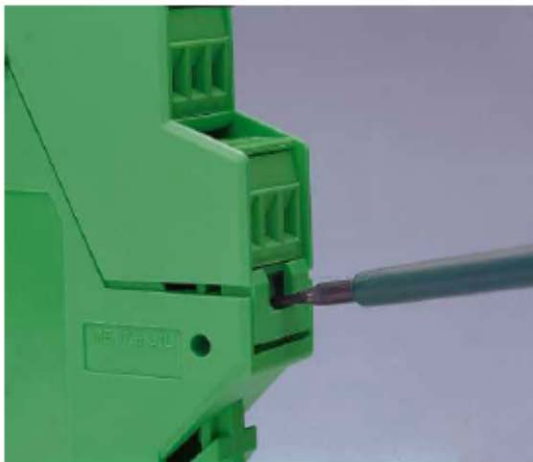

Operation Manual

LDM-1000 LVDT/RVDT Signal Conditioning Module

In order to begin the setup process, you must first know a few basic characteristics about the LVDT or RVDT you intend to use with the LDM-1000. The information may be obtained from the transducer calibration sheet, catalog literature, or the MEAS (Measurement Specialties, Inc.) web site at:

<http://www.meas-spec.com/position-sensors.aspx>

The list below is the minimum information required to perform a successful calibration:

- Recommended LVDT or RVDT excitation frequency (to set the oscillator frequency)
- LVDT or RVDT Output sensitivity at the excitation frequency (to set the gain)
- Primary (input) impedance at the excitation frequency (to set the oscillator output voltage)
- The \pm full scale linear or angular range over which you intend to perform the calibration
- Analog output signal required by your application

4.1 Supply Voltage

The LDM-1000 supply voltage range is 18~30 VDC with the JP1 jumper in the storage position (as shipped position). Only this range (18~30VDC) can be used for 4-20mA output operation. The operating voltage may be changed to 10~18 VDC by installing internal jumper JP1 across both pins. See the diagrams below for jumper settings.

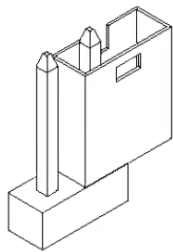

JP1 JUMPER SHOWN IN STORAGE POSITION
(AS SHIPPED)
SUPPLY VOLTAGE RANGE: 18 TO 30 VDC

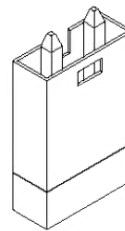

JP1 JUMPER SHOWN INSTALLED
ACROSS BOTH PINS
SUPPLY VOLTAGE RANGE: 10 TO 18 VDC

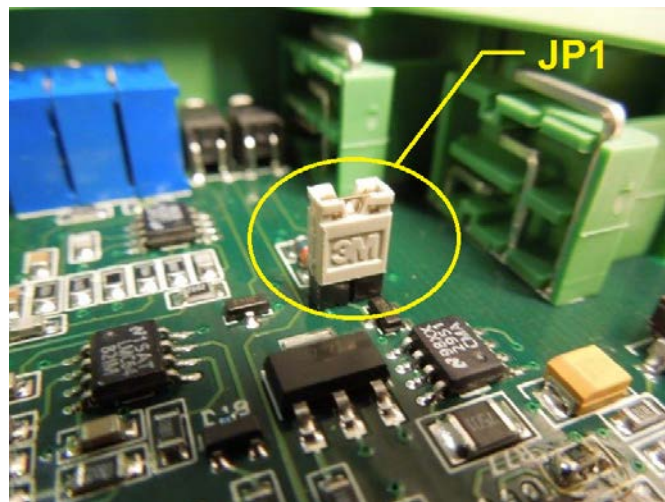

CAUTION: Operating the unit at voltages above +18 volts with the jumper in the low voltage position will overheat the internal voltage regulators and reduce the operational life of the LDM-1000.

Operation Manual

LDM-1000 LVDT/RVDT Signal Conditioning Module

4.2 Internal Switches

There are two internal DIP switch sets (SW1 and SW2) on the PC board assembly of the LDM-1000. The tables below explain the switch positions and functions.

Switch Set SW1									
Function:	Offset		Signal Bandwidth			Gain 2	Gain 1		
Switch No:	1	2	3	4	5	6	7	8	
Switch ON:	Positive	Negative	1 kHz	1 kHz	1 kHz	LOW	Switch position		Gain
Switch OFF:	None	None	250 HZ	250 HZ	250 HZ	HIGH			
<i>Note: Switches 3, 4 & 5 must be in same position</i>							OFF	OFF	x0.4
							OFF	ON	x1.2
							ON	OFF	x3.63
							ON	ON	x4.43

Switch Set SW2									
Function:	Oscillator Frequency			Sync	Osc. V		Output Range VDC		
Switch No:	1	2		3	4	5	6	7	8
Frequency	Switch Position		Switch ON:	INT	1 VRMS		0~5	±5	0~10
10 kHz	ON	ON	Switch OFF:	EXT	3 VRMS		Only one switch ON		
5 kHz	OFF	ON	4 to 20mA output works with any setting						
2.5 kHz	OFF	OFF							

Notes: Default factory settings are noted in BLUE in the above tables. Switch No. 5 of SW2 is not used. 3VRMS excitation is available only with the 18~30VDC supply voltage setting.

4.3 Oscillator Frequency:

Once you have established the proper excitation frequency for your transducer, refer to the tables below to set the LDM-1000 oscillator frequency.

For 2.5 KHz excitation (default factory setting):

Switch Set SW2		
Function:	Oscillator Frequency	
Switch No:	1	2
2.5kHz	OFF	OFF

Switch Set SW1			
Function:	Signal Bandwidth		
Switch No:	3	4	5
250 HZ	OFF	OFF	OFF

For 5 KHz excitation:

Switch Set SW2		
Function:	Oscillator Frequency	
Switch No:	1	2
5kHz	OFF	ON

Switch Set SW1			
Function:	Signal Bandwidth		
Switch No:	3	4	5
250 HZ	OFF	OFF	OFF

For 10 KHz excitation:

LDM-1000 LVDT/RVDT Signal Conditioning Module

Switch Set SW2		
Function:	Oscillator Frequency	
Switch No:	1	2
10 kHz	ON	ON

Switch Set SW1			
Function:	Signal Bandwidth		
Switch No:	3	4	5
1 kHz	ON	ON	ON

Note: The 1 kHz bandwidth setting is not recommended for excitation frequencies other than 10 kHz, otherwise significant noise will be present on the output signal and performance will be degraded.

4.4 Oscillator 'Sync' Mode

The Oscillator 'Sync' mode setting will depend on the number of LDM-1000's and transducers in your system, and their physical locations. For a single LVDT or RVDT system you will be running the LDM-1000 in the Master (INT) mode. For systems with multiple LDM-1000's, especially when they are co-located, and/or the interconnect cables between the LDM-1000's and the transducers run identical paths, it is recommended to Master and Slave the LDM-1000 oscillators to prevent beat frequencies and crosstalk between amplifiers and transducers. You will be selecting one LDM-1000 to serve as the Master oscillator (INT), and the balance will be set-up in the Slave mode (EXT).

CAUTION: Attempting to synchronize two LDM-1000 set as masters (factory default setting) may damage one or both units. Only one unit can be set to Master mode (INT, SW2 Switch 3 ON), otherwise damage to the electronics may result (See connection diagrams). All other units must be in the Slave mode (EXT, SW2 Switch 3 OFF).

Connecting Pins 11 (Sync OUT) and 12 (Sync COM) of the barrier strip, from unit to unit, will complete the sync bus circuit (See connection diagrams). The power common serves as the return line. Use the table below to configure your oscillator mode:

SW2-3	Mode
OFF	SLAVE
ON	MASTER

4.5 Oscillator Drive Capability

To ensure LVDT/RVDT compatibility with the LDM-1000 you must know the transducer current draw. The LDM-1000 is designed with a robust sine wave oscillator; it is rated for a maximum drive current of 25mA RMS with a voltage amplitude of 1 or 3 VRMS.

Therefore, you will need to know the LVDT/RVDT transducer input impedance for the frequency at which you intend to operate it. With the (factory default) 3 VRMS oscillator voltage, the transducer input impedance must be equal to or greater than 120 Ohms, which will result in current draw of 25mA or less. If the impedance of the transducer is lower, the 1 VRMS setting must be selected; with this setting, the LDM-1000 will be able to operate with impedances as low as 40 Ohms. The input impedance information is available on the datasheets for all MEAS LVDTs and RVDTs.

5 Setting the Amplifier Gain

You will need to calculate the LVDT or RVDT full scale output, using the simple formula below:

LVDT/RVDT sensitivity (in V/V/inch or V/V/degree), at the selected frequency, multiplied with the excitation voltage, (1 or 3 VRMS for the LDM-1000), multiplied with the full scale of the LVDT in inches (or RVDT in degrees).

As an example, the calculation for a MEAS HR1000 LVDT (± 1 inch range; 1 inch full scale), with a sensitivity of 0.39V/V/inch at 2.5KHZ, with 3 VRMS excitation would be done as follows:

$$0.39 \times 3 \times 1 = 1.17 \text{ VRMS full scale output or } 1.17 \text{ VRMS at } \pm 1 \text{ inch}$$

Using the table below, select the gain settings (switch numbers 6, 7 and 8 of SW1) for the range your full scale output falls into. In our example, you would use x0.4 HIGH.

Gain	Gain 1		Gain 2		LVDT Full Scale Output, VRMS
	SW1-7	SW1-8	Gain Lo/Hi	SW1-6	
x0.4	OFF	OFF	LOW	ON	1.20 to 2.50
x0.4	OFF	OFF	HIGH	OFF	0.78 to 1.20
x1.2	OFF	ON	LOW	ON	0.40 to 0.78
x1.2	OFF	ON	HIGH	OFF	0.26 to 0.40
x3.63	ON	OFF	LOW	ON	0.13 to 0.26
x3.63	ON	OFF	HIGH	OFF	0.10 to 0.13
x4.43	ON	ON	HIGH	OFF	0.05 to 0.10

LDM-1000 LVDT/RVDT Signal Conditioning Module

6 Dimensions and Wiring Terminals

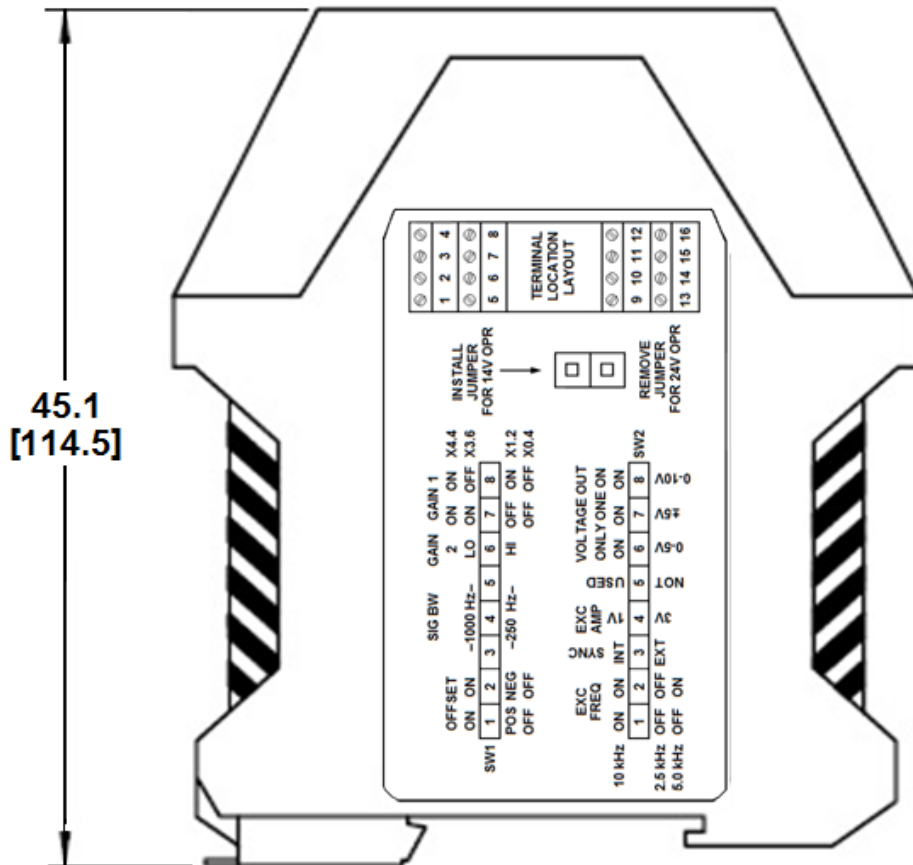
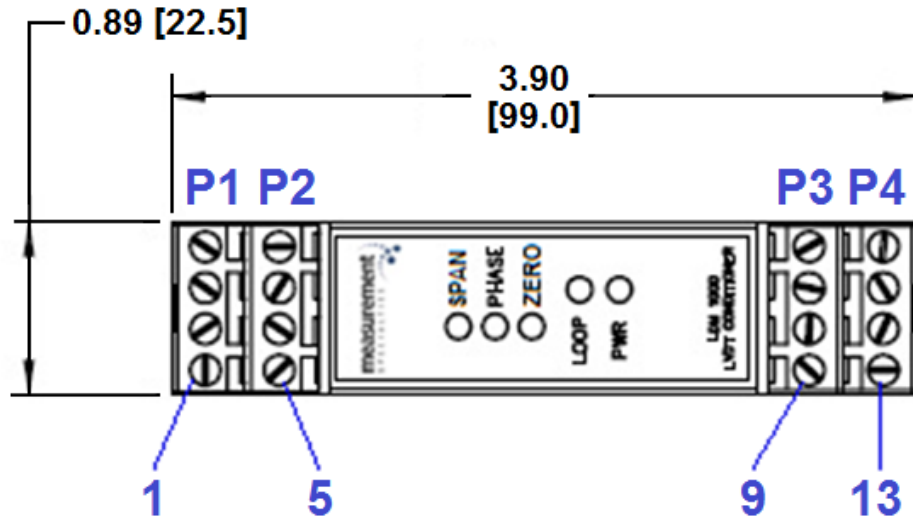

LDM-1000 LVDT/RVDT Signal Conditioning Module

7 Connection Diagrams

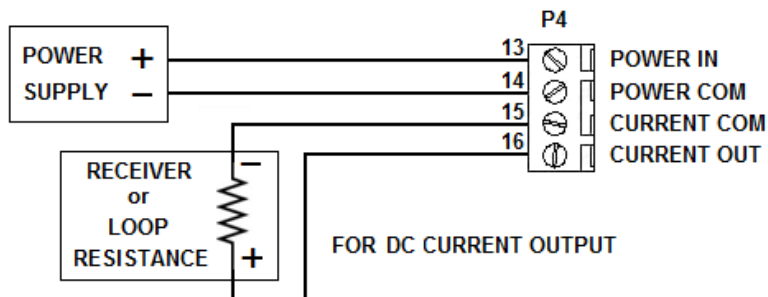
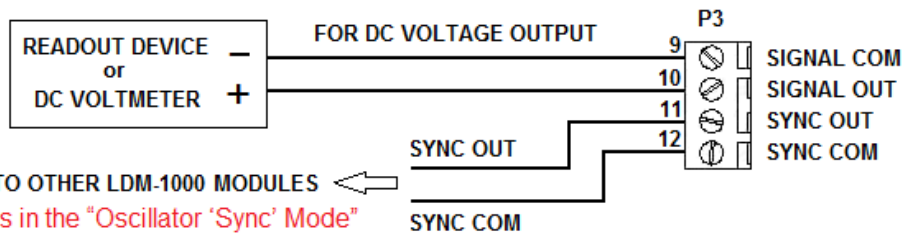
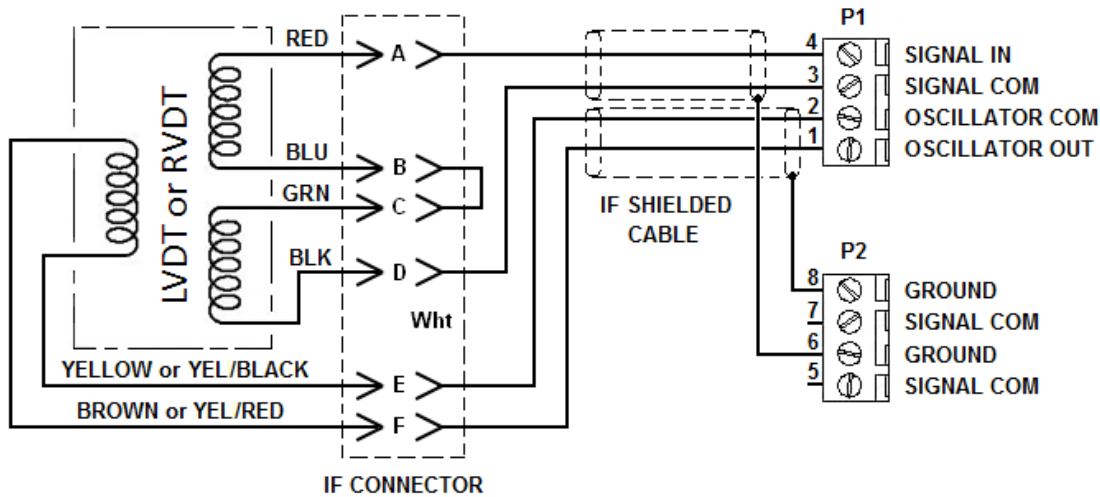

8 Calibration Procedure

Using the P1 and P2 terminal blocks according to the “Connection Diagrams” section of this manual, connect the LVDT or RVDT, a DC voltmeter, and a power supply (see “Supply Voltage” under the “Initial Setup Procedure” section of this manual) to the LDM-1000. Turn the power on and allow a 15 minute warm-up.

1. Disconnect the LVDT/RVDT primary wire from Terminal 1 of P1.
2. Adjust the ZERO potentiometer on the front panel until:
 - the DC voltage output between terminals 9 (SIGNAL COM) and 10 (SIGNAL OUT)
 - or the DC current between terminals 15 (CURRENT COM) and 16 (CURRENT OUT)reads in the middle of the range (see “Internal Switches” under the “Initial Setup Procedure” section of this manual for output DC voltage range selection); the middle of the ranges are as follows:
 - a. 0.0 VDC mid-range reading for ± 5 VDC Output
 - b. 2.5 VDC mid-range reading for 0 to +5 VDC output
 - c. 5.0 VDC mid-range reading for 0 to +10 VDC output
 - d. 12.0mA mid-range reading for 4 to 20mA output
3. Reconnect the LVDT/RVDT primary wire to Terminal 1 or P1
4. Insert the LVDT core into the middle of the bore, or rotate the RVDT shaft to the approximate center of the mechanical range, until the output reads as close to the mid-range DC voltage or current as possible (see mid-range readings in Step 2. above). If this adjustment is mechanically difficult or impractical, approximate the correct position as closely as possible, and then adjust the ZERO potentiometer until the output reads the middle of the range (see mid-range readings in Step 2. above).

Note: Changing course gain settings (DIP switches) after this step may result in a zero shift. Should you find it necessary to change the gain, you should repeat steps 1 through 4.

5. Displace the core of the LVDT or rotate the RVDT shaft in a positive direction (increasing DC voltage between terminals 9 and 10 or increasing DC current between 15 and 16) to approximately 80% of the full scale position you used in your calculation in “Setting the Amplifier Gain”.
6. Adjust the front panel PHASE potentiometer in the direction that increases the DC output signal until the maximum output is reached; if the output does not peak and the PHASE potentiometer is at the end of its adjustment range, leave it there and continue the calibration procedure.

Note: If at any point during the phase adjustment the output exceeds the maximum output limit of the selected range, reduce the output back to a 70-80% level by adjusting the front panel SPAN potentiometer, then continue with the phase adjust operation.

7. Return the LVDT core or the RVDT shaft back to the original center position. If the exact same mid-range DC output as in Step 2 above is not observed, slightly re-adjust of the ZERO potentiometer.
8. Using a precision positioning device, displace the LVDT core or rotate the RVDT shaft in a positive direction to the full scale position used in your calculation.

Note: The calibration can be made over a percentage of full scale by moving the core xx% of full scale and adjusting the output for the same percentage.

Operation Manual

LDM-1000 LVDT/RVDT Signal Conditioning Module

- Adjust the front panel SPAN potentiometer for the required positive full scale DC output (usually the maximum output limit of the selected range, in Step 2 above).

Note: If the required full-scale reading cannot be obtained by adjusting the SPAN potentiometer, the gain of the signal conditioner can be reset by changing the internal switches (see the "Setting the Amplifier Gain" section): If the SPAN potentiometer is fully counter clockwise, change to the next higher gain. If the SPAN potentiometer is fully clockwise, change to the next lower gain.

- Return the LVDT core or the RVDT shaft back to the original center position and re-check the output reading (should be the same mid-range reading as in Step 2 above). If needed, use the ZERO potentiometer to make a small adjustment.
- Displace the LVDT core or rotate the RVDT shaft to the negative full scale position (lowest output DC voltage or current); it should match the minimum reading for the range selected in Step 2 above. If needed, use the SPAN potentiometer to make a small adjustment.

Note: Due to symmetry errors of all LVDTs and RVDTs, the exact minimum and maximum output readings are rarely obtained.

9 Additional Information

Measurement Specialties, Inc. (NASDAQ MEAS) offers many other types of sensors and signal conditioners. Data sheets can be downloaded from our web site at: <http://www.meas-spec.com/datasheets.aspx>

MEAS acquired Schaevitz Sensors and the **Schaevitz**™ trademark in 2000.

TECHNICAL CONTACT INFORMATION

NORTH AMERICA	EUROPE	ASIA
Measurement Specialties, Inc. 1000 Lucas Way Hampton, VA 23666 United States Phone: +1-800-745-8008 Fax: +1-757-766-4297 Email: sales@meas-spec.com Web: www.meas-spec.com	MEAS Deutschland GmbH Hauert 13 D-44227 Dortmund Germany Phone: +49-(0)231-9740-0 Fax: +49-(0)231-9740-20 Email: info.de@meas-spec.com Web: www.meas-spec.com	Measurement Specialties China Ltd. No. 26, Langshan Road High-tech Park (North) Nanshan District, Shenzhen 518057 China Phone: +86-755-33305088 Fax: +86-755-33305099 Email: info.cn@meas-spec.com Web: www.meas-spec.com

The information in this sheet has been carefully reviewed and is believed to be accurate; however, no responsibility is assumed for inaccuracies. Furthermore, this information does not convey to the purchaser of such devices any license under the patent rights to the manufacturer. Measurement Specialties, Inc. reserves the right to make changes without further notice to any product herein. Measurement Specialties, Inc. makes no warranty, representation or guarantee regarding the suitability of its product for any particular purpose, nor does Measurement Specialties, Inc. assume any liability arising out of the application or use of any product or circuit and specifically disclaims any and all liability, including without limitation consequential or incidental damages. Typical parameters can and do vary in different applications. All operating parameters must be validated for each customer application by customer's technical experts. Measurement Specialties, Inc. does not convey any license under its patent rights nor the rights of others.

DEALER / REVENDEDOR

Brazil and South America / Brasil e América do Sul



Address / Endereço:

Rua Sete de Setembro, 2656
13560-181 - São Carlos - SP
Brazil / Brasil

Phone / Telefone:

+55 (16) 3371-0112
+55 (16) 3372-7800

Internet:

www.metrolog.net
metrolog@metrolog.net

www.metrolog.net