

ICA4 S and H Versions Strain Gauge or Load Cell Embedded Analogue Amplifier

User Manual
mantracourt.com

ME mantracourt

ICA4 S and H Versions Manual

Contents

Introduction to the ICAS and ICAH Range of In-Cell Amplifiers	2
Chapter 1 The ICAS and H Range	3
Figure 1.1 Block Diagram	3
Chapter 2 Installing the ICA4 S and H	4
Pre Installation	4
Figure 2.1 Dimensions	4
Power Connections	5
Figure 2.2 Connection Details for the ICA4 - Source mode	5
Figure 2.3 Connection Details for the ICA4 - Sink mode	5
Figure 2.4 Connection Details for Best EMC Immunity	5
Table 2.1	6
Output Connections	6
Chapter 3: Calculating the gain resistor value	7
Formula 3.1: To set the mV/V figure LOWER than 2.5 (increase the gain)	7
Formula 3.2 To set the mV/V figure HIGHER than 2.5 (decrease the gain) or issue 1 PCB	7
Chapter 4	8
Figure 4.1 Connection Details for Calibration	8
Chapter 5 Trouble Shooting	9
Chapter 6 Product Care	10
Chapter 7 Glossary	11
Chapter 8 Specifications for the ICA4S and ICA4H	13
Table 8.1 ICA4S and ICA4H (4 to 20mA)	13
Environmental	13
Measurement	13
CE Approvals	13
Other Mantracourt Products	14

Introduction to the ICAS and ICAH Range of In-Cell Amplifiers

Two new families, the ICAS (industrial stability) and ICAH (high stability) have been introduced into the Mantracourt range of In-Cell Amplifiers. They offer improved performance and easier installation over the original designs.

The following points detail the main changes:

- The ICA1 and ICA2 output ranges have been changed to cover 0.1V to 10.1V and 0.1V to 5.1V respectively to facilitate calibration and interpretation of the output level.
The linearity has been improved at the lower end of the scale (down to 70mV output).
- Excitation is standardised at 5V DC on the ICA1,2,3,4 and 6.
- The performance of the ICA family has been much improved over the operating temperature range by using high performance, auto-zero amplifiers and low drift resistors.
The standard ('S') versions give a 200% improvement compared to the earlier versions.
The high performance ('H') versions are fitted with higher-specification resistors to offer a 400% improvement over the earlier versions.
- The user-selectable span resistor is mounted via two standard plated through holes in the printed circuit board making it easier to change if required.
There is also provision for a second resistor (not normally fitted) to give an offset zero if required for example, 5.1V \pm 5V for an ICA1.
- All wire connections are via plated through holes instead of the single-sided pads used in the original design. This allows all wires to enter from either side of the board resulting easier installation and improved joint reliability.
- Multi-layer printed circuit boards and additional filtering has been added to further improve the EMC performance.
- Faster and easier mounting/installation: The mounting hole size and position has been standardised on all models and also provides the capacitive-coupling connection to the sensor body which further improves the EMC performance.
The hole will accommodate a 2mm (#0-80) screw with adequate clearance for the head.
As this mounting method is compatible with our range of 'D-Cell' products, a single pocket design will accept either digital or analogue conditioners.
- An ATEX (Intrinsic Safety) certified version of the ICA5 has been introduced.
- All variants are RoHS compliant.
- All models have a reduced height of just 7.6mm. The diameter remains at 19.5mm.
- A new model, the ICA6 has been introduced which will provide a \pm 10 Volt output from a uni-polar 15 to 28V supply.
- Non-interaction between the trimmers makes calibration easier and faster.

Chapter 1 The ICAS and H Range

Figure 1.1 Block Diagram

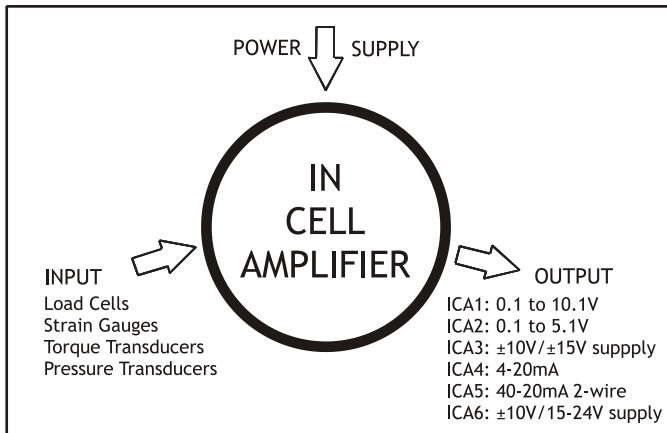

The ICA is a Strain Gauge Amplifier, converting a strain gauge input to a Volt or mA output - otherwise known as a Signal Conditioner.

The ICA provides a wide range of signal conditioning for Strain Gauges, Load Cells, Pressure and Torque Transducers.

Offered in 6 versions and two performance categories, ICAS and ICAH. The ICAH offers lower drift over the operating temperature range.

- ICA1 - 3 wire - 0.1 to 10.1V
- ICA2 - 3 wire - 0.1 to 5.1V
- ICA3 - 4 wire - $\pm 10V / \pm 15V$ supply
- ICA4 - 3 wire - 4 to 20mA
- ICA5 - 2 wire - 4 to 20mA
- ICA6 - 3 wire - $\pm 10V / 15-24V$ supply

This manual only deals with Version ICA4 S and H, separate manuals exists for versions ICA1 & 2, ICA3 & 6 and ICA5.

Transducer **SENSITIVITY** of between 0.5 mV/V and 150mV/V are possible. It is optimised to 2.5 mV/V. This range covers most - but not all - strain gauges.

Sensitivity adjustment is achieved by a combination of gain (span) resistor 'R' change and associated *fine adjustment* by potentiometer.

Similarly transducer **ZERO** can be compensated for in the module. This adjustment is to compensate for slight errors in the strain gauge and not to offset tare.

Mantracourt's SGA (Strain Gauge Amplifier) covers a range from 0.06 mV/V to 30mV/V and it's 79% offset can provide tare compensation.

Chapter 2 Installing the ICA4 S and H

Pre Installation

See Specification details in Chapter 8 for details of Environmental Approvals.

Carefully remove the ICA unit from its shipment box. Check that the unit is complete and undamaged.

The ICA units can be operated in any industrial environment providing the following limits are not exceeded.

Operating Temperature	-40°C to +85°C
Humidity	95% non condensing
Storage temperature	-40°C to +85°C

The following installation practices are advised:

- Minimise vibration
- Do not mount next to strong electrical fields (transformers, power cables)
- Ensure easy access to the module
- Install electrical protection device as the unit is not internally fused
- Always ensure the package is secure and protected

Figure 2.1 Dimensions

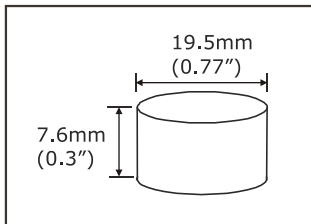

The module is designed to fit in the strain gauge pocket. Use the 2.1mm hole to secure the unit if required. The mounting hole will accept an M2 screw or American equivalent #0-80. Important Note: DO NOT USE #2 screw size.

Take care soldering cables to the pads.

Use a temperature controlled soldering iron set to a maximum 330 °C, for no longer than 2 seconds per pad. Excessive heat or increased soldering time may result in damage to the PCB.

If changing resistor 'R' do so at a workbench and not on site.

Check the relevant details for model ICA4, - ensure the module matches the instructions -

The ICA4 solder pads are as shown in the wiring diagrams:

4 pads for the strain gauge

2 pads for power supply

2 pads are for output

2 pads for linking the required mode

The fixing screw hole provides a ground connection to improve EMC performance.

Power Connections

The power supply for the ICA4 is 24V dc (within the limits of 13V to 28 V).

Figure 2.2 Connection Details for the ICA4 - Source mode

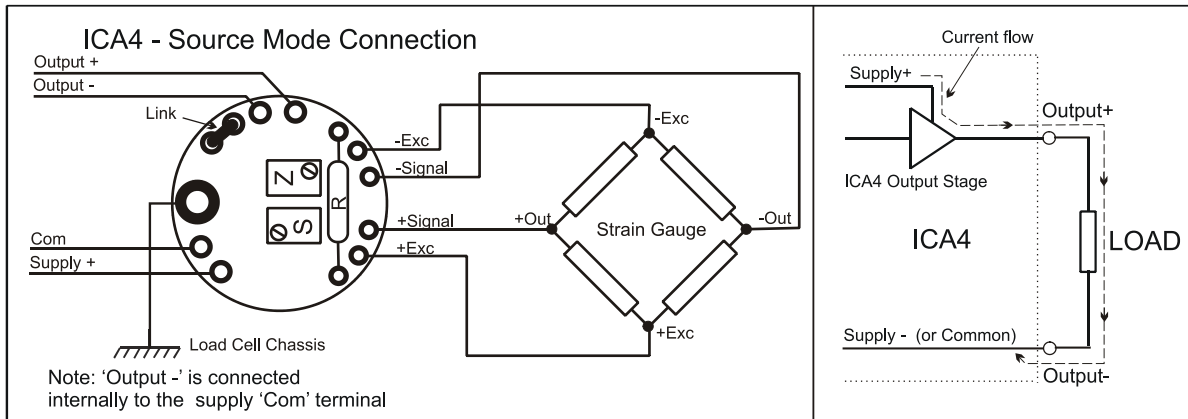

Figure 2.3 Connection Details for the ICA4 - Sink mode

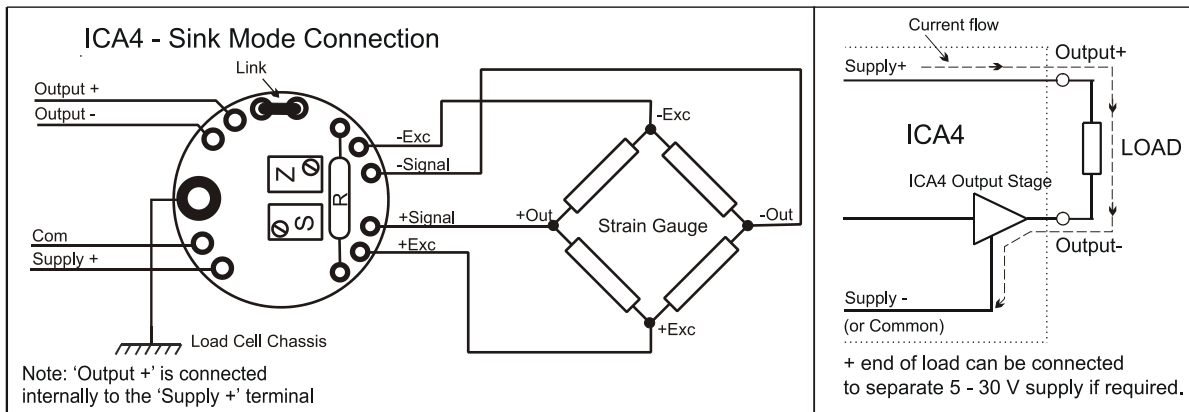
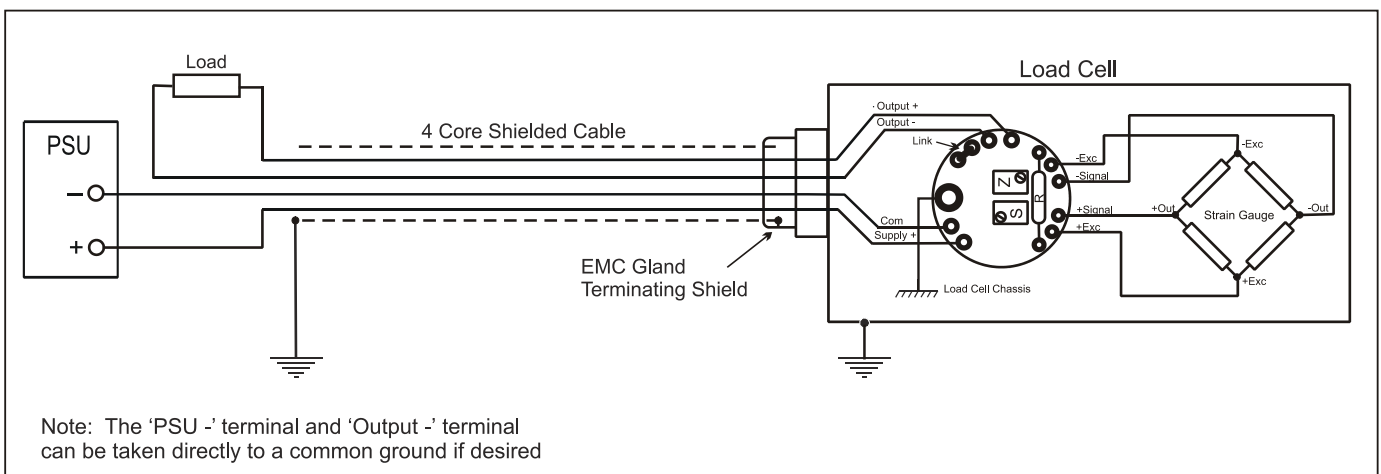

Figure 2.4 Connection Details for Best EMC Immunity



Take note of the grounding arrangement particularly the bolt hole which capacitively couples the common of the ICA electronics to the strain elements in the load cell which improves the EMC performance.

The ICA4 can be used with three wire cabling in both sink and source mode. The only difference between the two modes is whether the common end of the load is connected to the positive of the PSU (sink mode) or the negative of the PSU (source mode).

Table 2.1

This typical cable data is provided for information only.

The cable should have 2 x twin twisted cables. Ideally with each pair individually shielded and with an overall shield.

Country	Supplier	Part No	Description
UK	Farnell	118-2117	Individually shielded twisted multipair cable (7/0.25mm)- 2 pair Tinned copper drain. Individually shielded in polyester tape. Diameter: 4.1mm Capacitance/m: core to core 115 pF & core to shield 203 pF
UK	Farnell	585-646	Individually shielded twisted multipair cable (7/0.25mm)- 3 pair Tinned copper drain. Individually shielded in polyester tape. Diameter: 8.1mm Capacitance/m: core to core 98 pF & core to shield 180 pF
UK	RS	626-4761	Braided shielded twisted multipair cable (7/0.2mm)- 1 pair Miniature- twin -round Diameter: 5.2 mm Capacitance/m: core to core 230 pF & core to shield 215 pF

If possible segregate the signal cable from Power Cables; allow a 1metre (3 foot) distance from such cables.

Do not run signal cable in parallel with power cables and cross such cables at right angles.

The ground connection conductor should have sufficient cross-sectional area to ensure a low impedance path to attenuate RF interference.

Output Connections

The ICA4 analogue output is 4 to 20 mA (other modules in the ICA range offer DC voltage outputs).

The DC current output supports both 'sink' and 'source' modes of operation. A link provides the means of selecting the desired mode. (See Figures 2.2 and 2.3 for details).

In 'Source' mode the positive end of the load is connected to the ICA4 output "+" terminal and the current is 'sourced' by the ICA4 output (via the external supply) through the load towards ground (0V). This mode has the advantage that the negative output connection is common to the load cell '- Excitation' terminal.

In 'Sink' mode the positive end of the load is connected to the positive of the power supply (a separate external power supply may be used if desired) and the negative end of the load is connected to the ICA4 output "-" terminal. The current through the load is 'sunk' by the ICA4 towards the negative of the supply (0V). When in this mode, neither connection to the output load is electrically common to the load cell.

Note. If the ICA4 is required to operate in source mode (common negative - as per the Figure 2.2) then the above 4-wire cabling should be adhered to in order to provide the ICA4 with maximum protection. If, however a 3 wire cabling installation is required or unavoidable, the on-board protection circuit will limit the fault current in the load to approximately 55mA in the event of the negative supply connection to the ICA4 becoming open circuit.

Chapter 3: Calculating the gain resistor value

The ICA4 In-Cell strain gauge amplifier is supplied un-calibrated but optimised for a sensitivity of 2.5mV/V. To accommodate other sensitivities the gain resistor 'R' must be fitted (see Figure 2.2). The value of R is calculated using the formulae below.

N.B. a high quality component e.g. 1% 25 ppm metal film resistor should be used for optimum performance (the 'H' versions should use 10-15 ppm metal film devices to maintain their temperature drift performance). It may be necessary to use an E96 value to optimise the trim range.

Use the appropriate formula below depending on whether the ICA4 needs to be adjusted for a higher or lower mV/V sensitivity.

N.B. From issue 2 PCBs onwards, two surface mount gain resistors are fitted instead of the leaded type (see diagram). If your ICA4 does not have pads for these resistors then the PCB will be an older issue 1. In this case use formula 3.2 below.

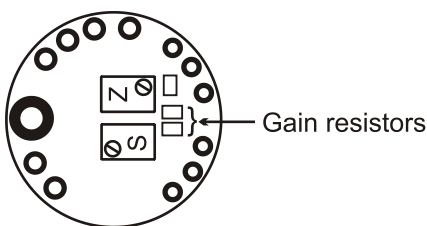

Formula 3.1: To set the mV/V figure LOWER than 2.5 (increase the gain)

To match a LOWER mV/V setting, use the following formulae:

$$Gain = \left(\frac{160}{\text{required mV/V}} \right) \quad R_x = \left(\frac{63,200}{(Gain - 1)} \right) \text{ Ohms} \quad R = \left(\frac{1}{\left(\frac{1}{R_x} - 0.001 \right)} \right) \text{ Ohms}$$

e.g. for 2.0mV/V Gain = 80 R = 4000 Ohms (use preferred value 3k9 or 4k02 (E96))

Formula 3.2 To set the mV/V figure HIGHER than 2.5 (decrease the gain) or issue 1 PCB

If the gain of the ICA4 needs to be reduced i.e. to match a HIGHER mV/V setting then the two surface mount gain resistors shown above must be removed and the following formulae used to calculate the new value for the gain resistor:

$$Gain = \left(\frac{160}{\text{required mV/V}} \right) \quad R = \left(\frac{63,200}{(Gain - 1)} \right) \text{ Ohms}$$

e.g. for 5.0mV/V Gain = 32 R = 2039 Ohms (use preferred value 2k or 2k05 (E96))

The new gain resistor should be fitted in position 'R' as shown in Figure 2.2

Chapter 4

Figure 4.1 Connection Details for Calibration

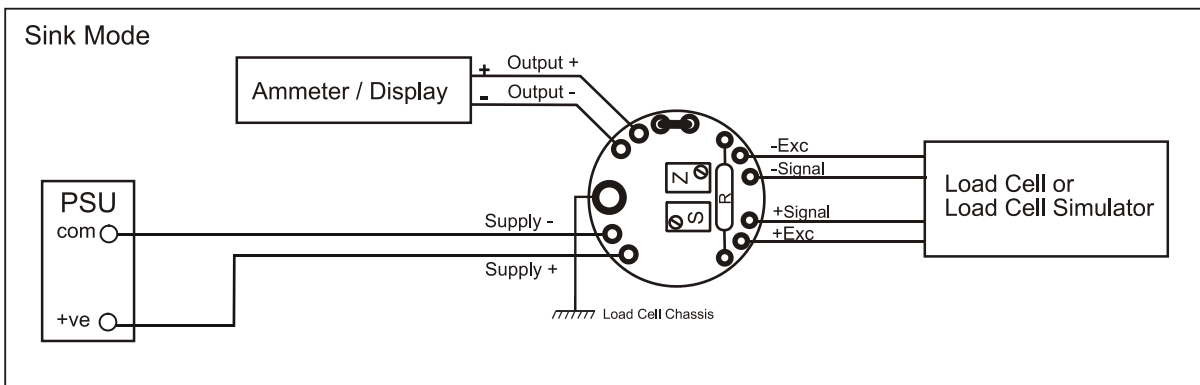
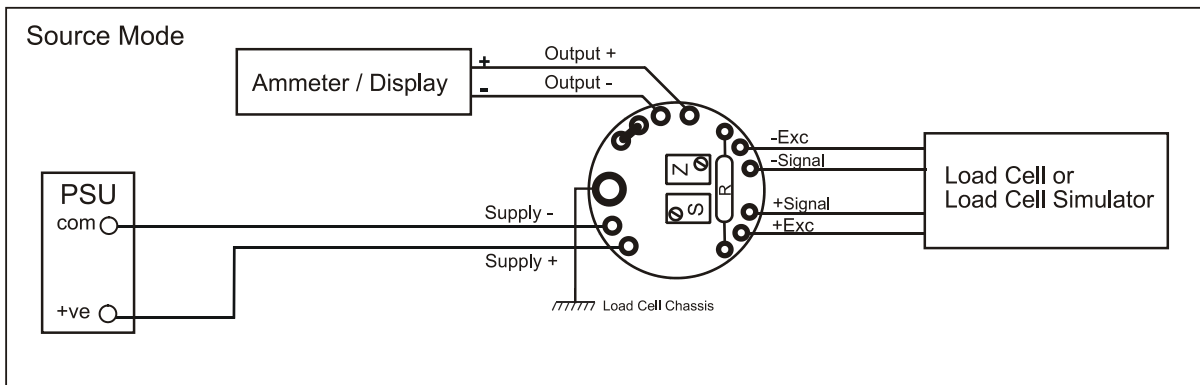

1. Apply the known **low** calibration conditions (weight, force or mV/V). This may be zero if required, and set the output to 4mA using the 'Z' potentiometer. Note the exact reading.
2. Apply the known **high** calibration conditions (ideally between 75% and full scale) and adjust the 'S' potentiometer to give an increase in output of 16mA.
3. Apply the known **low** calibration conditions and re-adjust the Zero if required.

Chapter 5 Trouble Shooting

1. No Output

- a) Check power supply is present and the correct polarity
- b) Check the output connections are correct with no open circuit connections
- c) Check terminations (ensure there are no dry joints)
- d) Check the sensor is connected (typically reading 350 Ohm across output + & -) with the power off
- e) Check the Excitation voltage is correct
- f) Check the load is connected and is not open or short circuited
- g) Check Span and Gain calibration

2. Low Output

This is when an output is present but not of sufficient magnitude to meet the required value. Remember to allow for Tare Weight and ensure it is measured and allowed for in the output from the ICA.

- a) Check power supply is within specified limits (i.e. is not low)
- b) Check the sensor is connected (typically reading 350 Ohm across output + & -) with the power off.
- c) Check the Excitation voltage is at 5V dc
- d) Check the calibration
- e) Check the Zero (offset) is correct for the sensor, this too is a common reason for low outputs

3. High Output

This is when an output is present but higher (in span or zero) than expected.

High output is not normally a problem. It is most likely to be incorrect connections and as such the output would be high and fixed

- a) Check the sensor is connected (typically reading 350 Ohm across output + & -) with the power off
- b) Check the Excitation voltage is at 5V dc
- c) Check the Zero (offset)
- d) Check the calibration.

4. Unstable Output

This is when the output is unstable or varies. The cause could be (a) poor installation or (b) a noisy environment.

Poor Installation -This is when an output is present but higher or lower (in span or zero) than expected:

- a) Check the installation for problems and repair where necessary
- b) Poor termination
- c) High resistance on cable leads
- d) Low insulation impedance
- e) Proximity to High Voltage Equipment - Transformers, Contactors, Motors etc.

Noisy Environment-

- a) Check if the source can be found and remove noise
- b) Check the cable shielding and ensure it is correctly installed and terminated.

5. Calibration

This section assumes that the unit is providing an output that is not stuck at top or bottom of the scale.

(See paragraphs 1-3 if this is the case)

Ensure you are connected to the correct sensor and not to another adjacent unit.

Ensure you have the correct calibration data from the sensor manufacturer. This must include a certified table with offset, zero and linearity.

Ensure you have the calibration set-up correctly installed i.e. mV source and output as required.

Ensure the temperature and other environmental parameters are within specification and where necessary taken into account when calibrating should such parameters have an effect on the calibration.

6. Fine Span (Gain) and Zero (Offset) Adjustment Problems

If the adjustment cannot reach the maximum output desired then, check the tare is not too high.

If the potentiometer does not alter the output the unit must be repaired - remove from service.

It is always wise to check a known good ICA against the problem installation before rejecting the suspect ICA.

Chapter 6 Product Care

A worn out component, excessive use in harsh environments, an overly zealous operator; regrettably some circumstances necessitate repair.

At Mantracourt Electronics Ltd we can't guarantee that a product will never require repairing. We can, however, promise a repair service of exceptional quality, one which is governed by a rigorous procedure.

Detailed below is our pledge to you: a defined set of ground rules and procedures to which we will adhere. All we ask in return is that you assist us with our procedure, such that we can maintain our promise to you. Please note that warranty repairs may not be available on overdue accounts, and that a strict interpretation of our conditions of trading invalidates warranty claims where late payment has occurred.

Please refer to 'Customer Repair Service Procedure' document - contact your distributor for a copy.

In the unlikely event you have problems with the ICA module we would advise that you take the following precautions:-

- The unit is installed as instructed.
- Recommended spares are kept in stock. We can assist.
- Sufficient expertise available for first line maintenance.
- Routine maintenance checks are performed - annually is recommended.
- The necessary documentation for the product is available to the maintenance personnel.

We recommend you keep on file - as a minimum

- This Manual
- The calibration figures for the attached sensors
- A record of the 'normal' output - if applicable
- A calibration record of the ICA
- A contact phone number from the supplier for assistance

Chapter 7 Glossary

AWG	American Wire Gauge.
Background Noise	The total noise floor from all sources of interference in a measurement system, independent of the presence of a data signal. (See Noise)
Bipolar	The ability of a signal conditioner to display both positive and negative readings.
Bridge Resistance	The resistance measured across the excitation terminals of a Strain Gauge.
Calibration	Adjustment of an instrument or compiling a deviation chart so that it's reading can be correlated to the actual value being measured.
CMR (Common-Mode Rejection)	The ability of an instrument to eliminate the effect of AC or DC noise between signal and ground. Normally expressed in dB at DC to 60 Hz. One type of CMR is specified between SIG LO and PWR GND. In differential meters, a second type of CMR is specified between SIG LO and ANA GND (METER GND).
Common Mode Rejection Ratio	The ability of an instrument to reject interference from a common voltage at its input terminals with relation to ground. Usually expressed in db (decibels).
Drift	Change of a reading/set point value over periods due to several factors including change in ambient temperature, time and line voltage.
Excitation	The external application of electrical voltage current applied to a transducer for normal operation.
Fine Adjustment	Zero and Span calibration have a Fine Adjustment to give accuracy to the calibration. These are potentiometers P1 and P2 for Span and Zero respectively.
Full Bridge	A Wheatstone Bridge configuration utilizing four active elements or Strain Gauges.
Full Range Output	The algebraic difference between the minimum output and maximum output.
Gain	Gain is otherwise identified as SPAN. It relates to the proportional output to the sensor input. Calibration of the ICA is determined by setting the Gain (Span) and Offset (Zero). The amount of amplification used in an electrical circuit.
Ground	The electrical neutral line having the same potential as the surrounding ground.
Linearity	The closeness of a calibration curve to a specified straight line. Linearity is expressed as the maximum deviation of any calibration point on a specified straight line during any one calibration cycle.
Load	The electrical demand of a process expressed as power (watts), current (amps) or resistance (ohms).
Load Impedance	The impedance presented to the output terminals of a transducer by the associated external circuitry.
Load Cell	The load cell is one of a series of STRAIN GAUGE sensors that the ICA input is designed to accept. (Torque Sensor, Pressure & temperature transducers).
Millivolt	One thousandth of a volt, 10^{-3} volts symbol mV.
Noise	An unwanted electrical interference on the signal wires.
Null	A condition, such as balance, which results in a minimum absolute value of output.
Offset	Offset is otherwise identified as ZERO. Calibration of the ICA is determined by setting the Offset (Zero) and Gain (Span).
Potentiometer	Two potentiometers (variable resistors) are used in the ICA1 & 2 for fine calibration.
Pressure Transducer	The Pressure Transducer is one of a series of Strain Gauge sensors that the ICA input is designed to accept. (Torque Sensor, Load Cell and Temperature Transducers).
Proportional Outputs	The Voltage or Current outputs are calibrated to be directly proportional to the input from the sensor. The output is, within the sensor limits, taken as linear and no linearity compensation is required within the ICA.

Resolution	The input corresponding to a one-unit change in the least significant digit of the data acquisition/display equipment. (Good resolution is not necessarily equal to good accuracy.)
Sensing Element	That part of the Transducer, which reacts directly in response to the input.
Sensitivity	This is the relationship between the change in Strain Gauge input to the level or magnitude of the output.
Signal Conditioner	A circuit module that offsets attenuates, amplifies linearizes and/or filters the signal. The ICA is essentially a Signal Conditioner -more specifically known as a Strain Gauge Amplifier - in that it CONDITIONS (alters) the input signal from a load cell to an electrical output.
Single Card Assembly	The ICA has only the one Printed Circuit Board assembly on which all the components are mounted. The assembly is then mounted inside an environmentally rugged enclosure.
Span	Span is otherwise identified as GAIN. It relates to the proportional output to the sensor input. Calibration of the ICA is determined by setting the Span (Gain) and Zero (Offset).
Span Adjustment	The ability to adjust the gain of a process or strain meter so that a specified display span in engineering units corresponds to a specified signal span.
Stability	The quality of an instrument or sensor to maintain a consistent output when a constant input is applied.
Strain Gauge	The Strain Gauge is a resistance bridge device where the bridge value alters linearly and proportionally to the force exerted on it - be it pressure, torque or load. The ICA is designed to convert this change in the of the Strain Gauge to a proportional electrical signal.
Strain Gauge Amplifier	The ICA4 is essentially a type of Signal Conditioner that it conditions (alters) the input signal from a strain gauge to an electrical output
Torque Transducer	The Torque Transducer is one of a series of Strain Gauge sensors that the ICA input is designed to accept.
Wheatstone Bridge	A network of four resistance's, an emf source, and a galvanometer connected such that when the four resistance's are matched, the galvanometer will show a zero deflection or "null" reading.
Zero	Zero is otherwise identified as OFFSET. It relates to the proportional output to the sensor input. Calibration of the ICA is determined by setting the Span (Gain) and Zero (Offset).
Zero Adjustment	The ability to adjust the display of a process or strain meter so that zero on the display corresponds to a non-zero signal.
Zero Offset	The difference between true Zero and an indication given by a measuring instrument. See Zero Suppression.
Zero Suppression	The Span is Offset from Zero (Zero Suppressed) such that neither limit of the Span will be Zero. For example, an instrument which measures a load of a 100kG Span from 400kG to 500kG is said to have 400kG Zero Suppression.
Units	
AC	Alternating Current
DC	Direct Current
Hz	Hertz (Frequency)
kHz	kiloHertz (Frequency)
mA	milliamps
mm	millimetres
SC	Signal Conditioner
ICA	Strain Gauge Amplifier
V	Volts
mV	millivolt

Chapter 8 Specifications for the ICA4S and ICA4H

Table 8.1 ICA4S and ICA4H (4 to 20mA)

Environmental

Parameter	Minimum	Typical	Maximum	Units	Notes
Supply voltage Range	13	24	30	Volts	
Operating Current	-	8	-	mA	Note 1
Operating Temperature Range	-40	-	85	Deg C	
Storage Temperature Range	-40	-	85	Deg C	
Reverse polarity Protection	-30	-	-	Volts	

Note 1: Not including excitation current and output current.

e.g. when connected to a 350 Ohm load cell:-

Total current = Operating current (8mA) + Excitation current ($5/350 = 14\text{mA}$) + Output current (20mA FS) = 42mA FS (typical).

Measurement

Parameter	Minimum	Typical	Maximum	Units	Notes
Bridge Excitation	4.90	5	5.10	Volts	
Bridge Impedance	350	1000	5000	Ohms	
Bridge Sensitivity	0.5	2.5	150	mV/V	Note 1
Output load	-	-	1000	Ohms	Note 2
Bandwidth	DC	-	1000	Hz	
'Zero' adjustment	-	± 2	-	%FR	
'Span' adjustment	-	± 8	-	%FR	
Linearity	-	0.02	-	%FR	
Temperature stability					
'Zero' Temperature Stability ('S' Version)	-	0.0009	0.0025	+/-%FR/Deg C	At 2.5mV/V
'Span' Temperature Stability ('S' Version)	-	0.0025	0.0064	+/-%FR/Deg C	At 2.5mV/V
'Zero' Temperature Stability ('H' Version)	-	0.0004	0.0015	+/-%FR/Deg C	At 2.5mV/V
'Span' Temperature Stability ('H' Version)	-	0.002	0.0051	+/-%FR/Deg C	At 2.5mV/V

FR=Full Range (16mA)

Note 1: Set by calibration resistor

Note 2: 24V minimum supply/sink mode.

CE Approvals

European EMC Directive

2004/108/EC

BS EN 61326-1:2006

BS EN 61326-2-3:2006

Other Mantracourt Products

mantracourt.com

Signal Conditioning

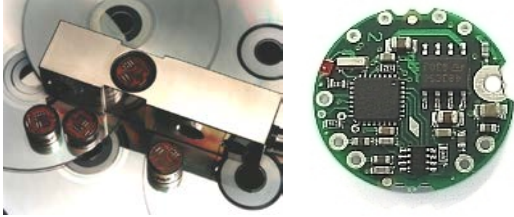
<p>SGA STRAIN GAUGE AMPLIFIER</p> <ul style="list-style-type: none"> • Connect up to 4 strain gauges • Proportional mA and/or Voltage output • Simple DIL switch configuration • Set Sensitivity and Low pass filter and output • Simple - Reliable - Rugged 	
<p>LCA IN-LINE INTELLIGENT STRAIN GAUGE AMPLIFIER</p> <ul style="list-style-type: none"> • 2 Set Points • 4 to 20 mA AND 0 to 10 V (isolated) outputs • RS 232/485 Communications port • On-Board easy to use Programmer • Auto tare-Auto calibrate-and much more..... 	<p>ADW15 Mantraweigh 72 mm DIN Module - Display & Controller</p> <ul style="list-style-type: none"> • 10 mm LED Display (Configurable) • Sensitivity from 0.5 mV to 200 mV/V • 10 V @150 mA Excitation • Isolated I/O100mSec sample rate • Set Point Relays • 4 to 20 mA Output • Programmable via keypad
<p>FIELDBUS CONNECTIVITY IN TWO EXCELLENT PACKAGES</p>	
<p>DSC The Digital Strain Card</p>	<p>'D'Cell The 'in-cell' Digital Strain Puck</p>
	
<p>Mount this package adjacent to the strain gauge Plug-in-and-go-sensor</p>	<p>Mount this package directly into the strain gauge pocket High accuracy</p>
<p>Integrate the electronics with the loadcell, remove the cost, space and bother of additional electronics and have a direct output provided in REAL ENGINEERING UNITS.</p>	<p>A quantum leap in the quality of measurement.</p>
	<p>Accuracy (1 part in half a million) Temperature compensated Unwanted Signal noise filter Sensor specific calibration Elimination of induced noise on signals</p>



In the interests of continued product development, Mantracourt Electronics Limited reserves the right to alter product specifications without prior notice.

Doc No. 517-177	Issue 1.5	11.04.14
-----------------	-----------	----------

Distribuidor

Brasil e América do Sul

CONTATO

Endereço

Rua Sete de Setembro, 2656 - Centro
13560-181 - São Carlos - SP - Brasil

Telefone

+ 55 (16) 3371-0112
+ 55 (16) 3372-7800

Internet

www.metrolog.net
metrolog@metrolog.net

