

Model 8011 & 8021 4-20mA Accelerometer & Velocity Transmitter



Measurement Specialties, Inc.
Vibration Sensors Design Center
32 Journey, Suite 150
Aliso Viejo, CA 92656 USA
Tel: 949-716-7324

www.meas-spec.com
vibration@meas-spec.com

Warranty

Measurement Specialties, Inc. accelerometers are warranted during a period of one year from date of shipment to original purchaser to be free from defects in material and workmanship. The liability of Seller under this warranty is limited to replacing or repairing any instrument or component thereof which is returned by Buyer, at his expense, during such period and which has not been subjected to misuse, neglect, improper installation, repair, alteration, or accident. Seller shall have the right to final determination as to the existence and cause of a defect. In no event shall Seller be liable for collateral or consequential damages. This warrant is in lieu of any other warranty, expressed, implied, or statutory; and no agreement extending or modifying it will be binding upon Seller unless in writing and signed by a duly authorized officer.

Receiving Inspection

Every Measurement Specialties, Inc. accelerometer is carefully inspected and is in perfect working condition at the time of shipment. Each accelerometer should be checked as soon as it is received. If the unit is damaged in any way, or fails to operate, a claim should immediately be filed with the transportation company.

Service Concerns

If a Measurement Specialties, Inc. instrument requires service, first contact the nearest Measurement Specialties, Inc. representative. They may be able to solve the problem without returning the unit to the factory. If it is determined that factory service is required, call Customer Service at the regional headquarters for an RMA number before return.

Returns

All units being returned to the factory require an RMA (Return Material Authorization) number before they will be accepted. This number may

be obtained by calling Customer Service at the regional headquarters with the following information; model number(s), quantity, serial number(s), and symptoms of the problem, if being returned for service. You must include the original purchase order number if under warranty.

Recalibration Services

The Vibration Sensors Design Center and its two manufacturing facilities in China and France offer factory re-calibration services for Variable Capacitance, Piezoresistive, Piezoelectric (including IEPE, ICP etc.) accelerometers and Electronics. NIST (US), DKD (Germany), COFRAC (France) traceable calibration services on sensitivity at 100 Hz (102 or 120 Hz in Europe) and full frequency sweeps are offered. Contact the regional headquarters for pricing information.

Inquiries

Address all inquiries on operation or applications to your nearest Sales Representative, or to the Vibration Applications Support as follows:

Global Headquarters

1000 Lucas Way
Hampton, VA 23666, USA
Tel: +1 757 766 1500

Vibration Sensors Design Center

32 Journey, Suite 150
Aliso Viejo, CA 92656, USA
Tel: +1 949 716 7324

European Headquarters

Impasse Jeanne BENOZZI
CS 83 163, 31027 Toulouse Cedex 3, France
Tel: +33 (0) 582 08 22 00

Asian Headquarters

Measurement Specialties (China), Ltd.
No. 26 Langshan Road
Shenzhen High-Tech Park (North)
Nanshan District, Shenzhen 518057, China
Tel: +86 755 3330 5088

Description

The 4-20mA loop power model 8011 & 8021 accelerometers are available in either Acceleration or Velocity output options. Both models feature a welded Stainless Steel housing with either a 2-pin hermetic MIL-C-5015 connector or an integral cable.

The model 80XX-AR & 80XX-AP are the accelerometer variants available in ranges from $\pm 5g$ to $\pm 50g$, in either 4-20mA RMS or Peak acceleration output options. The accelerometers include internal shielding and a wide usable bandwidth to 5000Hz.

The 80XX-VR & 80XX-VP are the velocity transmitter variants available in ranges from 0.5 to 5.0 in/sec, in either 4-20mA RMS or Peak velocity output options. The velocity transmitters include internal shielding and a usable bandwidth to 1000Hz.

Part Number Configuration

The accelerometer part number configurations are illustrated below.

- 8011; Top exit connector
- 8012; Top exit integral cable
- 8021; Side exit connector
- 8022; Side exit integral cable

8011-XX-GGG-CCC (if required) -XX
 | | | Cable Length (0360 is 360 inches) AR or VR = RMS
 | | Range (080 is 80g, 05 is 0-0.5 in/sec) AP or VP = Peak
 | Range Type (AR is RMS Acceleration, VR is RMS Velocity)

Example: 8011-AR-080
 Model 8011, RMS Acceleration Output, 80g Range

Model	4-20mA Configuration	Ranges	Dash Number
8011		5g	-005
8012	AP, Acceleration Peak	10g	-010
8021	AR, Acceleration RMS	20g	-020
8022		50g	-050
8011		0.50in/sec	-05
8012	VP, Velocity Peak	1.00in/sec	-10
8021	VR, Velocity RMS	2.00in/sec	-20
8022		3.00in/sec	-30
		5.00in/sec	-50

Mounting Installation

The model 801X accelerometers are designed to be stud mounted while the model 802X accelerometers are designed to be screw mounted for optimum frequency response. However, the units can also be adhesively mounted with an adhesive mounting adaptor or mounted with a magnetic mounting adaptor for temporary installations (for 801X only)

Stud Mounting (model 801X)

For model 801X, the provided AC-A03663 stud should be used. This stud is designed for 1/4-28 thread mounting, please contact the factory for other stud adaptor options. The following guidelines should be followed:

- The mounting surface should be clean and free of any residue or foreign material.
- The mounting surface should be smooth, flat, and with a maximum surface roughness of 32 micro-inches rms.
- Apply a light coating of coupling fluid (machine oil or silicone grease) on the mating surface to maximize the usable frequency range.
- Torque mounting stud to 24 in-lbs (2.7 N-m)

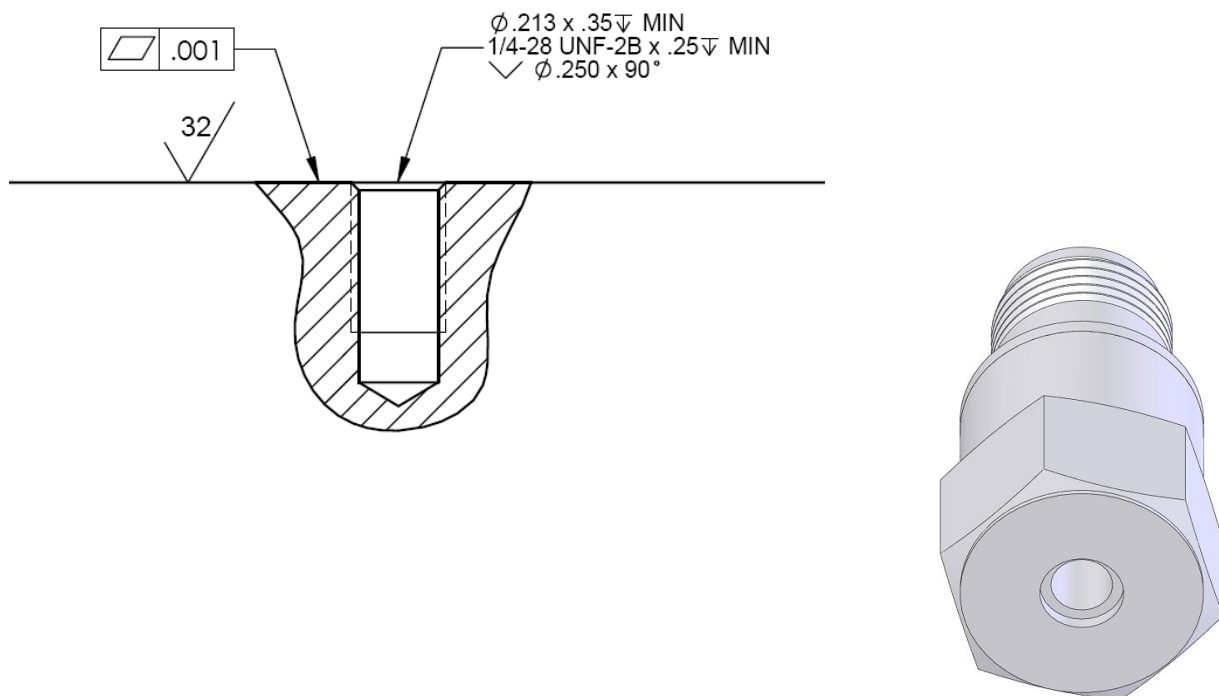

Screw Mounting (model 802X)

For model 802X, the captive screw AC-A03735 should be used. This screw is designed for 1/4-28 thread mounting, please contact factory for other captive screw options. The following guidelines should be followed:

- The mounting surface should be clean and free of any residue or foreign material.
- The mounting surface should be smooth, flat, and with a maximum surface roughness of 32 micro-inches rms.
- Apply a light coating of coupling fluid (machine oil or silicone grease) on the mating surface to maximize the usable frequency range.
- Torque mounting stud to 24 in-lbs (2.7 N-m)

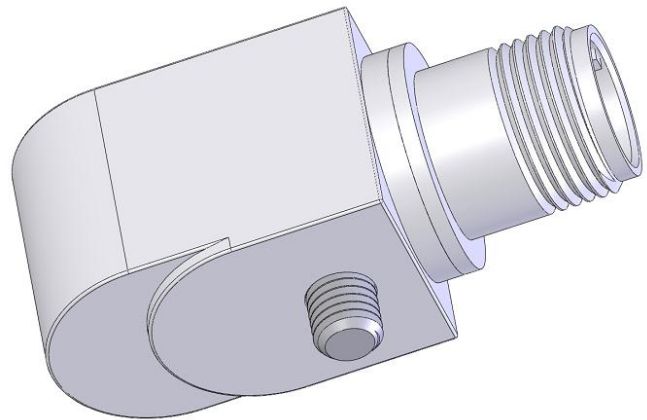
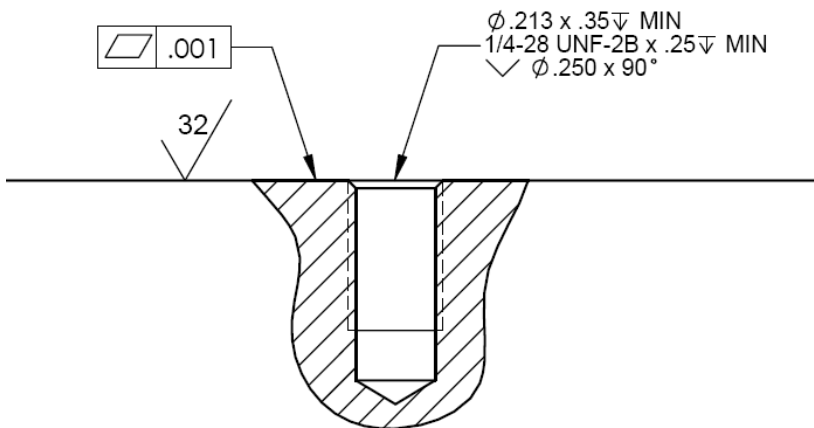

Adhesive Mounting

To avoid damaging the accelerometer during subsequent removal, it is recommended to use an adhesive mounting adaptor for this method of attachment. For adhesively mounting of accelerometers the following guidelines should be followed:

- The mounting surface should be clean and free of any residue or foreign material.
- The mounting surface should be smooth, flat, and with a maximum surface roughness of 64 micro-inches rms.
- For best high frequency performance a cyanoacrylate adhesive is recommend. A thin layer offers best frequency response.
- Soften adhesive cured adhesive with a chemical debonder (eg. acetone) prior to removal. Gently shear accelerometer loose from the mounting surface after waiting a few minutes for the debonding agent to penetrate the epoxy. Make sure not to use excessive force as this may damage the accelerometer.

Magnet Mounting

For magnetic mounting (model 801X only) a magnetic mounting adaptor should be used. Magnetic mounting offers a quick and easy installation portable installation method that is convenient for easy removals. For magnetic mounting of accelerometers the following guidelines should be followed:

- Verify that the mounting surface is magnetic and flat.
- The mounting surface should be clean and free of any residue or foreign material.
- The mounting surface should be smooth, flat, and with a maximum surface roughness of 64 micro-inches rms.
- Inspect the magnet surface of the adaptor which should also be clean and free of any residue or foreign material.
- Install the magnetic mounting adaptor on the accelerometer first. Torque to 24 in-lbs (2.7 N-m).
- Gently mount the accelerometer with adaptor to the mounting surface. Do NOT drop the accelerometer onto the mounting surface as this could potentially generate very high g-levels that can damage the accelerometer.
- Note that poor installation can drastically affect the frequency response of the accelerometer.

Cable Routing

The cable assembly should be properly secured at regular intervals. It is recommended to use clamps, wax, or tape to secure the cable to minimize cable motion that can add noise to the output signal. The initial attachment should be within two to three inches of the accelerometer.

Avoid routing cables near high-voltage wires and also ground the shield at the signal conditioner to minimize ground loops.

4-20mA Signal Output

The signal output from the 80XX sensor can be calculated using the following formulas.

80XX-AR & 80XX-AP Accelerometer

Vibration Level in G's = (Signal Output in mA – 4mA) x (Full Scale Range in G's / 16mA)

Typical outputs are illustrated in the tables below.

Signal Output	80XX-AR & 80XX-AP Accelerometer Ranges			
	5g	10g	20g	50g
4mA	0.00g	0.00g	0.0g	0.0g
8mA	1.25g	2.50g	5.0g	12.5g
12mA	2.50g	5.00g	10.0g	25.0g
16mA	3.75g	7.50g	15.0g	37.5g
20mA	5.00g	10.0g	20.0g	50.0g

80XX-VR & 80XX-VP Velocity Transmitter

Velocity Level in IPS (in/sec) = (Signal Output in mA – 4mA) x (Full Scale Range in IPS / 16mA)

Typical outputs are illustrated in the tables below.

Signal Output	80XX-VR & 80XX-VP Velocity Transmitter Ranges				
	0.50in/sec	1.00in/sec	2.00in/sec	3.00in/sec	5.00in/sec
4mA	0.00in/sec	0.00in/sec	0.00in/sec	0.00in/sec	0.00in/sec
8mA	0.125in/sec	0.25in/sec	0.50in/sec	0.75in/sec	1.25in/sec
12mA	0.25in/sec	0.50in/sec	1.00in/sec	1.50in/sec	2.50in/sec
16mA	0.375in/sec	0.75in/sec	1.50in/sec	2.25in/sec	3.75in/sec
20mA	0.50in/sec	1.00in/sec	2.00in/sec	3.00in/sec	5.00in/sec

System Installation

The loop powered model 80XX are designed to operate with 4-20mA read out devices or connected directly into a PLC/DCS Control System. A typical loop powered circuit and system installation are illustrated below.

Please note that if using a read out device, then the maximum loop resistance is controlled by the following equation. Use this equation to calculate maximum cable length.

$$\text{Maximum Loop Resistance} = (\text{Excitation Voltage} - 12\text{Vdc}) / 20\text{mA}$$

