

## Model 4810A Accelerometer

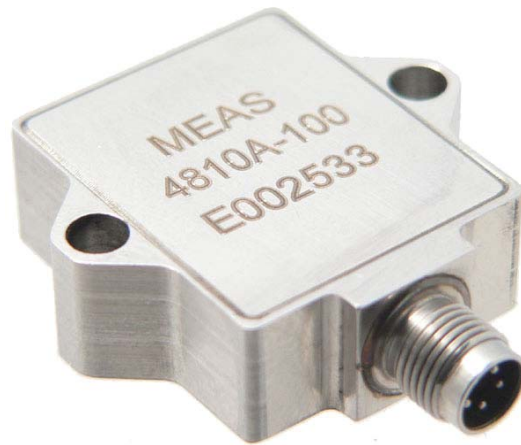

Measurement Specialties, Inc.  
Vibration Sensors Design Center  
32 Journey, Suite 150  
Aliso Viejo, CA 92656 USA  
Tel: 949-716-7324

[www.meas-spec.com](http://www.meas-spec.com)  
[vibration@meas-spec.com](mailto:vibration@meas-spec.com)

## Warranty

Measurement Specialties, Inc. accelerometers are warranted during a period of one year from date of shipment to original purchaser to be free from defects in material and workmanship. The liability of Seller under this warranty is limited to replacing or repairing any instrument or component thereof which is returned by Buyer, at his expense, during such period and which has not been subjected to misuse, neglect, improper installation, repair, alteration, or accident. Seller shall have the right to final determination as to the existence and cause of a defect. In no event shall Seller be liable for collateral or consequential damages. This warrant is in lieu of any other warranty, expressed, implied, or statutory; and no agreement extending or modifying it will be binding upon Seller unless in writing and signed by a duly authorized officer.

## Receiving Inspection

Every Measurement Specialties, Inc. accelerometer is carefully inspected and is in perfect working condition at the time of shipment. Each accelerometer should be checked as soon as it is received. If the unit is damaged in any way, or fails to operate, a claim should immediately be filed with the transportation company.

## Service Concerns

If a Measurement Specialties, Inc. instrument requires service, first contact the nearest Measurement Specialties, Inc. representative. They may be able to solve the problem without returning the unit to the factory. If it is determined that factory service is required, call Customer Service at the regional headquarters for an RMA number before return.

## Returns

All units being returned to the factory require an RMA (Return Material Authorization) number before they will be accepted. This number may

be obtained by calling Customer Service at the regional headquarters with the following information; model number(s), quantity, serial number(s), and symptoms of the problem, if being returned for service. You must include the original purchase order number if under warranty.

## Recalibration Services

The Vibration Sensors Design Center and its two manufacturing facilities in China and France offer factory re-calibration services for Piezoresistive, Piezoelectric and Integrated Electronics Piezoelectric (IEPE, ISOTRON, ICP, etc.) accelerometers. NIST (US), DKD (Germany), COFRAC (France) traceable calibration services on sensitivity at 100 Hz (102 or 120 Hz in Europe) and full frequency sweeps are offered. Contact the regional headquarters for pricing information.

## Inquiries

Address all inquiries on operation or applications to your nearest Sales Representative, or to the Vibration Applications Support as follows:

### *Global Headquarters*

1000 Lucas Way  
Hampton, VA 23666, USA  
Tel: +1 757 766 1500

### *Vibration Sensors Design Center*

32 Journey, Suite 150  
Aliso Viejo, CA 92656, USA  
Tel: +1 949 716 7324

### *European Headquarters*

Impasse Jeanne BENOZZI  
CS 83 163, 31027 Toulouse Cedex 3, France  
Tel: +33 (0) 582 08 22 00

### *Asian Headquarters*

Measurement Specialties (China), Ltd.  
No. 26 Langshan Road  
Shenzhen High-Tech Park (North)  
Nanshan District, Shenzhen 518057, China  
Tel: +86 755 3330 5088

## Description

The Model 4810A is a rugged, low profile DC response accelerometer packaged in a welded stainless steel housing with integral temperature compensation. The accelerometer incorporates a miniature side-mounted connector with a detachable mating cable assembly. The Model 4810A is offered in ranges from  $\pm 2$  to  $\pm 500g$  and incorporates gas damped silicon MEMS sensing elements with a wide bandwidth from DC up to 1500Hz.

## Installation

The model 4810A accelerometer is designed to be screw mounted but can also be adhesively mounted if the installation does not allow for screw mounting.

### *Screw Mounting*

For screw mounting of accelerometers the following guidelines should be followed:

- The mounting surface should be clean and free of any residue or foreign material.
- The mounting surface should be smooth, flat, and with a maximum surface roughness of 32 micro-inches rms.
- Optional: Apply a light coating of coupling fluid (machine oil or silicone grease) on the mating surface to maximize the usable frequency range.
- Torque screws to recommended limits using steel washers under the heads of the mounting screws. Use manual torque wrench (do not use electric tools).

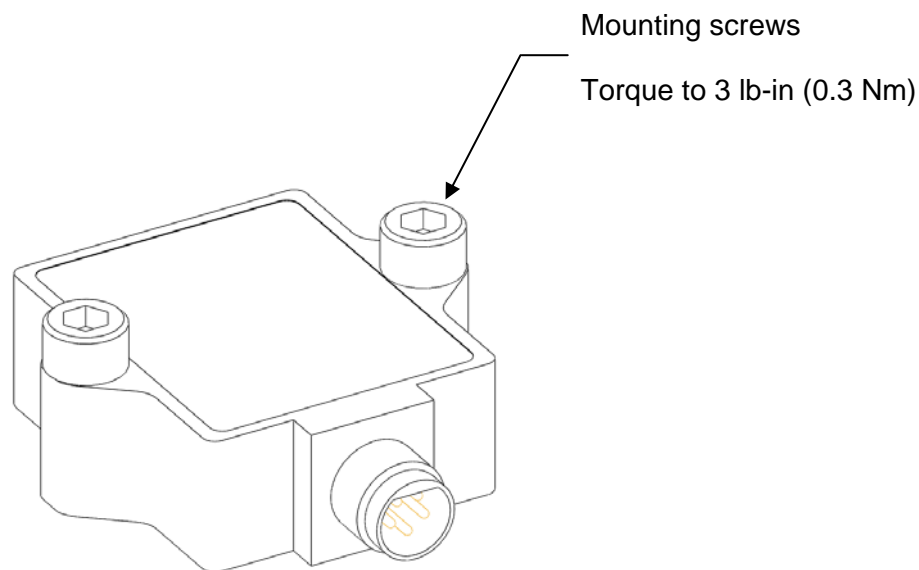

## *Adhesive Mounting*

To avoid damaging the accelerometer during subsequent removal, it is recommended to use an adhesive mounting adaptor for this method of attachment (model AC-D02744 adaptor is offered). For adhesively mounting of accelerometers the following guidelines should be followed:

- The mounting surface should be clean and free of any residue or foreign material.
- The mounting surface should be smooth, flat, and with a maximum surface roughness of 64 micro-inches rms.
- For best high frequency performance a cyanoacrylate adhesive is recommend. A thin layer offers best frequency response.
- Soften adhesive cured adhesive with a chemical debonder (eg. acetone) prior to removal. Gently shear accelerometer loose from the mounting surface after waiting a few minutes for the debonding agent to penetrate the epoxy. Make sure not to use excessive force as this may damage the accelerometer.

## *Triaxial Mounting*

For triaxial measurements it is recommended that the AC-D02652 triaxial mounting block is used. The triaxial block is supplied with both #8-36 UNF and M4x0.7 mounting screws. Alternatively, the triaxial block can also be mounted with a 10-32 UNF mounting stud.

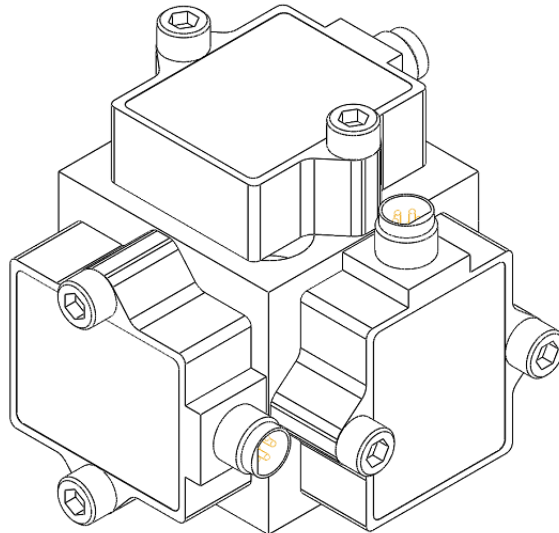

## Wiring

The accelerometer is designed to be operated from 8-36Vdc excitation and provide a  $\pm 2V$  full scale output with a 2.5V reference voltage. The output is DC-coupled and can be used in either single-ended or differential mode. Differential mode offers the best performance since common mode errors are minimized. The electrical hookup for both modes of operation is detailed below.

### Single-Ended Operation

For single-ended operation a 2.5Vdc bias will be present on the output leads and the output of the accelerometer will be 0.5-4.5V full scale. For single-ended operation the accelerometer should be connected to the signal conditioner as detailed below. **To avoid permanently damaging the accelerometer, the white wire should not be connected to ground.**

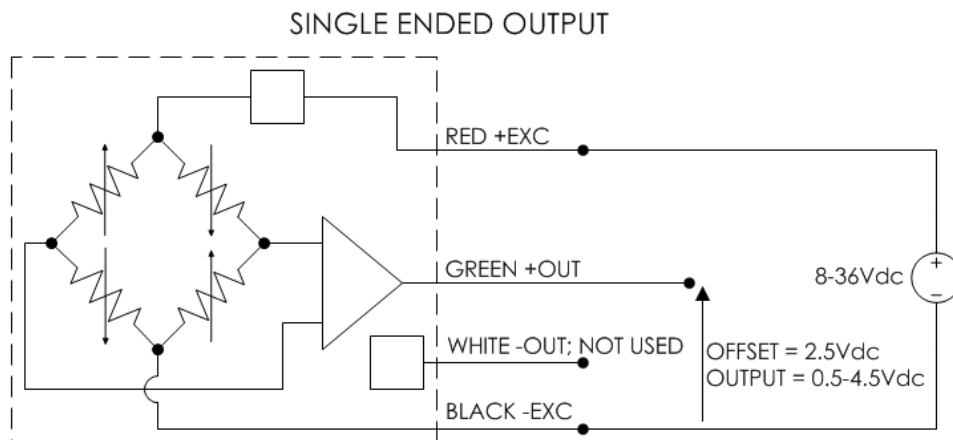

### Differential Operation

For differential operation the output of the accelerometer will be  $\pm 2V$  full scale without a bias voltage present. For differential operation the accelerometer should be connected to the signal conditioner as detailed below. Common mode voltage is 2.5V.

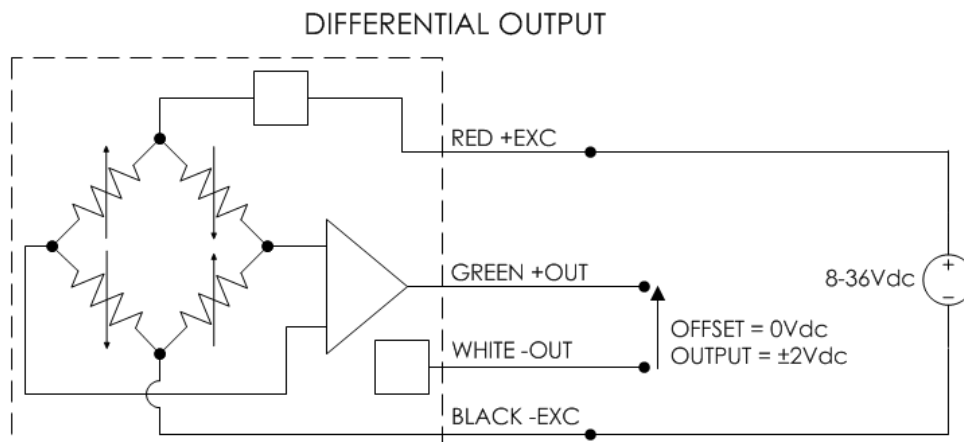

## Cable Routing

The model 4810A accelerometer incorporates a miniature side-mounted connector with a detachable mating cable assembly (model 340A). For reliable operation it is recommended that a small amount of thread locking compound is used to secure the connector plug during testing. For long term use in a wet or oily environment it is recommended that the connector interface is protected with a silicone sealant and a flexible heat shrink tubing.

The cable assembly should also be properly secured at regular intervals during testing. It is recommended to use clamps, wax, or tape to secure the cable to minimize cable motion that can add noise to the output signal. The initial attachment should be within two to three inches of the accelerometer with some slack in the cable to prevent tension at the connector joint

Avoid routing cables near high-voltage wires and also ground the shield at the signal conditioner to minimize ground loops. The housing of the 4810A has a conductive surface connected to the shell of its integral connector. Therefore, single-point grounding is required in order to prevent ground loops. If mounting the accelerometer to a structure that is not electrically isolated, the shield of the cable should be left floating at the signal conditioner.

# Operating Manual

## Noise Floor Specifications

The model 4810A accelerometer incorporates an ultra low-noise circuit which offers micro-g resolution. The noise specifications for this accelerometer are detailed in table below.

FULL SCALE RATING (g-pk)	SENSITIVITY (mV/g)	±5% AMPL PASSBAND (Hz)	PASSBAND NOISE (μVrms)	SPECTRAL NOISE (μg-rms/√Hz)	DYNAMIC RANGE (dB)
2	1000	200	500	35	72
5	400	300	300	38	76
10	200	400	300	75	76
20	100	700	350	132	75
50	40	1000	400	316	74
100	20	1500	400	516	74
200	10	1500	400	1033	74
500	4	1500	400	2582	74

## Frequency Response & Phase Deviation Curves

The typical frequency response and phase deviation curves for the model 4810A accelerometer are illustrated below.

