

Model 4332 Accelerometer



Measurement Specialties, Inc.
Vibration Sensors Design Center
32 Journey, Suite 150
Aliso Viejo, CA 92656 USA
Tel: 949-716-7324

www.meas-spec.com
vibration@meas-spec.com

Warranty

Measurement Specialties, Inc. accelerometers are warranted during a period of one year from date of shipment to original purchaser to be free from defects in material and workmanship. The liability of Seller under this warranty is limited to replacing or repairing any instrument or component thereof which is returned by Buyer, at his expense, during such period and which has not been subjected to misuse, neglect, improper installation, repair, alteration, or accident. Seller shall have the right to final determination as to the existence and cause of a defect. In no event shall Seller be liable for collateral or consequential damages. This warrant is in lieu of any other warranty, expressed, implied, or statutory; and no agreement extending or modifying it will be binding upon Seller unless in writing and signed by a duly authorized officer.

Receiving Inspection

Every Measurement Specialties, Inc. accelerometer is carefully inspected and is in perfect working condition at the time of shipment. Each accelerometer should be checked as soon as it is received. If the unit is damaged in any way, or fails to operate, a claim should immediately be filed with the transportation company.

Service Concerns

If a Measurement Specialties, Inc. instrument requires service, first contact the nearest Measurement Specialties, Inc. representative. They may be able to solve the problem without returning the unit to the factory. If it is determined that factory service is required, call Customer Service at the regional headquarters for an RMA number before return.

Returns

All units being returned to the factory require an RMA (Return Material Authorization) number before they will be accepted. This number may

be obtained by calling Customer Service at the regional headquarters with the following information; model number(s), quantity, serial number(s), and symptoms of the problem, if being returned for service. You must include the original purchase order number if under warranty.

Recalibration Services

The Vibration Sensors Design Center and its two manufacturing facilities in China and France offer factory re-calibration services for Piezoresistive, Piezoelectric and Integrated Electronics Piezoelectric (IEPE, ISOTRON, ICP, etc.) accelerometers. NIST (US), DKD (Germany), COFRAC (France) traceable calibration services on sensitivity at 100 Hz (102 or 120 Hz in Europe) and full frequency sweeps are offered. Contact the regional headquarters for pricing information.

Inquiries

Address all inquiries on operation or applications to your nearest Sales Representative, or to the Vibration Applications Support as follows:

Global Headquarters
1000 Lucas Way
Hampton, VA 23666, USA
Tel: +1 757 766 1500

Vibration Sensors Design Center
32 Journey, Suite 150
Aliso Viejo, CA 92656, USA
Tel: +1 949 716 7324

European Headquarters
Impasse Jeanne BENOZZI
CS 83 163, 31027 Toulouse Cedex 3, France
Tel: +33 (0) 582 08 22 00

Asian Headquarters
Measurement Specialties (China), Ltd.
No. 26 Langshan Road
Shenzhen High-Tech Park (North)
Nanshan District, Shenzhen 518057, China
Tel: +86 755 3330 5088

Description

The Model 4332 is a low noise triaxial amplified accelerometer packaged in a rugged aluminum housing with an integral cable assembly. The Model 4332 is offered in ranges from ± 2 to $\pm 20g$ and features gas damped MEMS sensing elements. The accelerometer has a set low-pass filter at 50Hz and an operating temperature range of -40°C to $+85^{\circ}\text{C}$. The accelerometer is also certified to IP68 protection up to 40m depth.

Installation

The model 4332 accelerometer is designed to be screw mounted but can also be adhesively mounted if the installation does not allow for screw mounting.

Screw Mounting

For screw mounting of accelerometers the following guidelines should be followed:

- The mounting surface should be clean and free of any residue or foreign material.
- The mounting surface should be smooth, flat, and with a maximum surface roughness of 32 micro-inches rms.
- Optional: Apply a light coating of coupling fluid (machine oil or silicone grease) on the mating surface to maximize the usable frequency range.
- Torque screws to recommended limits using steel washers under the heads of the mounting screws. Use manual torque wrench (do not use electric tools).

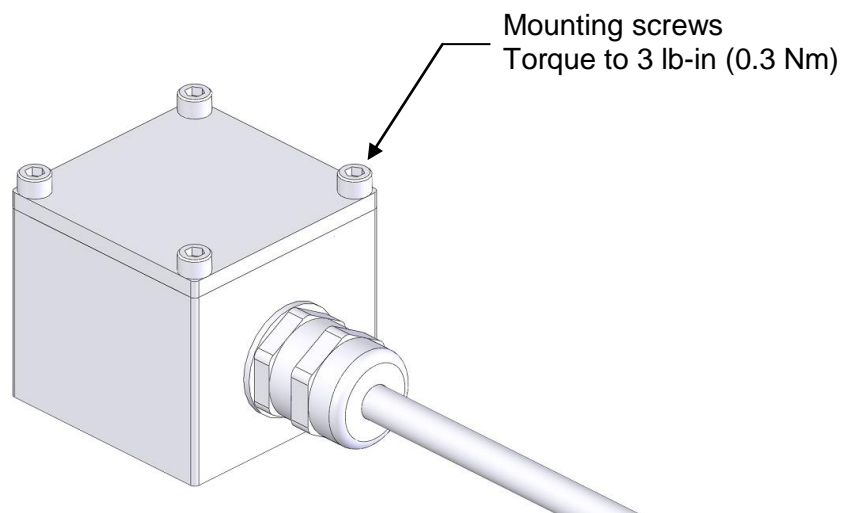

Operating Manual

Adhesive Mounting

To avoid damaging the accelerometer during subsequent removal, it is recommended to use an adhesive mounting adaptor for this method of attachment. For adhesively mounting of accelerometers the following guidelines should be followed:

- The mounting surface should be clean and free of any residue or foreign material.
- The mounting surface should be smooth, flat, and with a maximum surface roughness of 64 micro-inches rms.
- For best high frequency performance a cyanoacrylate adhesive is recommend. A thin layer offers best frequency response.
- Soften adhesive cured adhesive with a chemical debonder (eg. acetone) prior to removal. Gently shear accelerometer loose from the mounting surface after waiting a few minutes for the debonding agent to penetrate the epoxy. Make sure not to use excessive force as this may damage the accelerometer.

Operating Manual

Wiring

The accelerometer is designed to be operated from 5-30Vdc excitation and provides a 0.5 to 4.5V full scale output. The output is DC-coupled and should be used in single-ended mode. The electrical hookup for operation is detailed below.

A 2.5Vdc bias will be present on the output leads and the output of the accelerometer will be 0.5-4.5V full scale. The accelerometer should be connected to the interface circuitry as detailed below.

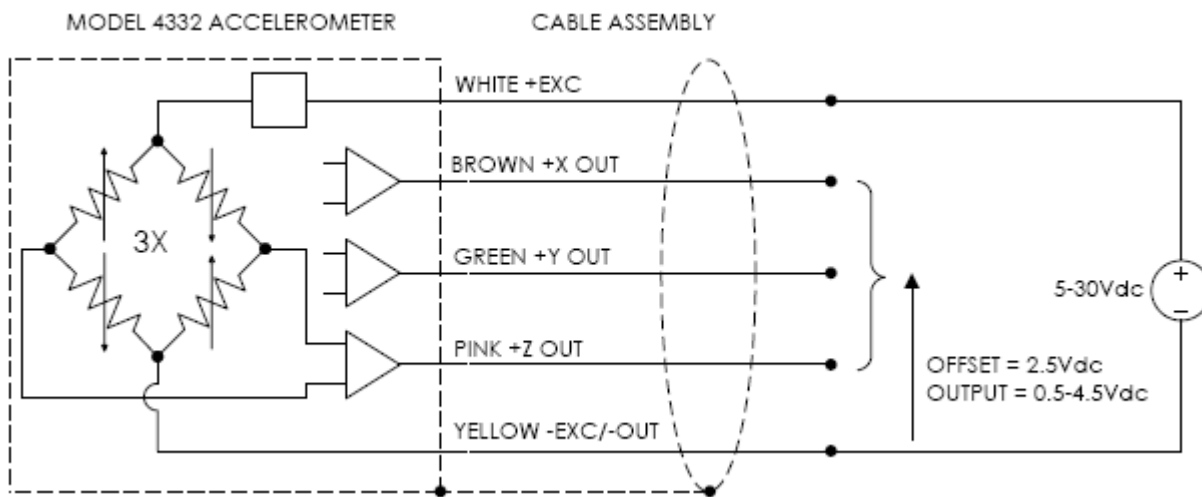

Cable Routing

The model 4332 accelerometer incorporates a PVC jacketed cable with an integral shield. The cable assembly should be properly secured at regular intervals during testing. It is recommended to use clamps, wax, or tape to secure the cable to minimize cable motion that can add noise to the output signal. The initial attachment should be within two to three inches of the accelerometer.

Avoid routing cables near high-voltage wires and also ground the shield at the signal conditioner to minimize ground loops.

Operating Manual

Noise Floor Specifications

The model 4332 accelerometer incorporates a LP filtered output for a high output signal. The noise specifications for this accelerometer are detailed in table below.

FULL SCALE RATING (g-pk)	SENSITIVITY (mV/g)	±5% AMPL PASSBAND (Hz)	PASSBAND NOISE (μVrms)	SPECTRAL NOISE (μg-rms/√Hz)	DYNAMIC RANGE (dB)
2	1000	20	80	8	88
5	400	20	50	13	92
10	200	200	200	71	80
20	100	200	200	141	80

Frequency Response Curves

The typical frequency response curves for the model 4332 accelerometer are illustrated below.

