

**SCHAEVITZ**  
**MP Series**  
**Microprocessor-Based**  
**LVDT Readout/Controller**



Operating Instructions • Installation Information

P/N:09290700-000

Printed in China

**North American Operations**

Schaevitz® Sensors  
1000 Lucas Way  
Hampton, Virginia 23666  
(800) 745-8008  
Fax: (757) 766-4297



# Microprocessor-Based LVDT Readout/Controller

## MP2000

### Warranty

Schaevitz instruments are warranted during a period of one year from date of shipment to original purchaser to be free from defects in material and workmanship. The liability of Seller under this warranty is limited to replacing or repairing any instrument or component there of which is returned by Buyer, at his expense, during such period and which has not been subjected to misuse, neglect, improper installation, repair, alteration, or accident. Seller shall have the right to final determination as to the existence and cause of a defect. In no event shall Seller be liable for collateral or consequential damages. This warrant is in lieu of any other warranty, expressed, implied, or statutory; and no agreement extending or modifying it will be binding upon Seller unless in writing and signed by a duly authorized officer.

### Receiving Inspection

Every Schaevitz instrument is carefully inspected and is in perfect working order at the time of shipment. Each instrument should be checked as soon as received. If the unit is damaged in any way, or fails to operate, a claim should immediately be filed with the transportation company.

### Service Concerns

If a Schaevitz instrument requires service, first contact the nearest Schaevitz Representative. He may be able to solve the problem without returning the unit to the factory. If it is determined that factory service is required, call the Repair Department for an RMA number before return.

### Returns

All units being returned to the factory require an RMA (Return Material Authorization) number before they will be accepted. This number may be obtained by calling the Repair Department at 1-800-745-8008 with the following information: model number, quantity, serial number, and symptoms of the problem, if being returned for service. You must include the original P.O. number or Schaevitz sales number if under warranty.

### Inquiries

Address all inquiries on operation or applications to your nearest Sales Representative, or to Sales Manager, Schaevitz Sensors, 1000 Lucas Way, Hampton, VA 23666, USA.

North America Tel: (800) 745-8008

# Table of Content

<b>1. Description .....</b>	<b>2</b>
1.1 General.....	2
1.2 Unit Description.....	2
<b>2. Installation and Wiring .....</b>	<b>4</b>
2.1 Installation.....	4
2.2 Input Power Supply.....	4
2.3 Input Signal Wiring.....	4
2.4 Output Wiring.....	8
<b>3. Controls, Adjustments and Indicators .....</b>	<b>10</b>
3.1 Settings of LVDT oscillation ( Voltage, Frequency).....	10
3.2 Sensitivity Setup.....	10
3.3 Front Panel Switches.....	13
<b>4. Operation Instructions .....</b>	<b>15</b>
<b>5. Calibration Instructions .....</b>	<b>22</b>
<b>6. RS232 Output .....</b>	<b>24</b>
6.1 General.....	25
6.2 RS232 Baud Rate Setting.....	25
6.3 RS232 Procedures .....	25
6.4 Data Format.....	28
<b>7. Glossary.....</b>	<b>30</b>
<b>Illustration List:</b>	
Figure 1 MP2000 Front Panel View.....	3
Figure 2 MP2000 Rear Panel View.....	3
Figure 3 Input Transducer Connections .....	6
Figure 4 Input Transducer Connections .....	7
Figure 5 Output Wiring .....	8
Figure 6 Output Wiring .....	9
Table A Sensitivity (Gain) Chart .....	12

# Microprocessor-Based LVDT Readout/Controller

## 1. Description

### 1.1 General

The Schaevitz MP2000, an integrated microprocessor-based LVDT readout controller is designed for the excitation and readout of AC operated linear variable differential transformers (LVDTs).

The readout/controller, is supplied with a 100 to 240 V ac. 50 to 60Hz. Universal external power supply. A US/Canadian approved power cord is also included. Although this device is CE approved for use in Europe, it is the responsibility of the customer to provide the proper approved mains supply cord, relevant for their country. The MP utilizes a 1/4 DIN standard form factor, and is supplied with all the necessary hardware for panel mounting. An optional bench top mount is available from the factory, for a small additional cost. Physical variables such as displacement, force and weight can be read out directly in engineering units on the 5 digit display, which reads up to 99999.

### 1.2 Unit Description

Figure 1 (MP2000 Front Panel View) and Figure 2 (MP2000 Rear Panel View) show the configuration of the unit.

#### Improvements to the new MP2000 include:

A bitmap LCD display with larger characters  
 A new, more efficient RS232 protocol  
 Soft switches replace the old mechanical dip switches on the rear panel for setting various oscillator and gain parameters  
 An upgraded floating point microprocessor  
 Overall improved factory floor reliability  
 Oversized power connector for tough operating environments

The RS-232 communications now interfaces through a standard 9-pin sub-D connector, to eliminate the need to fabricate special cables. Communication continues to be available on the 25-pin multi-function I/O connector, as well.

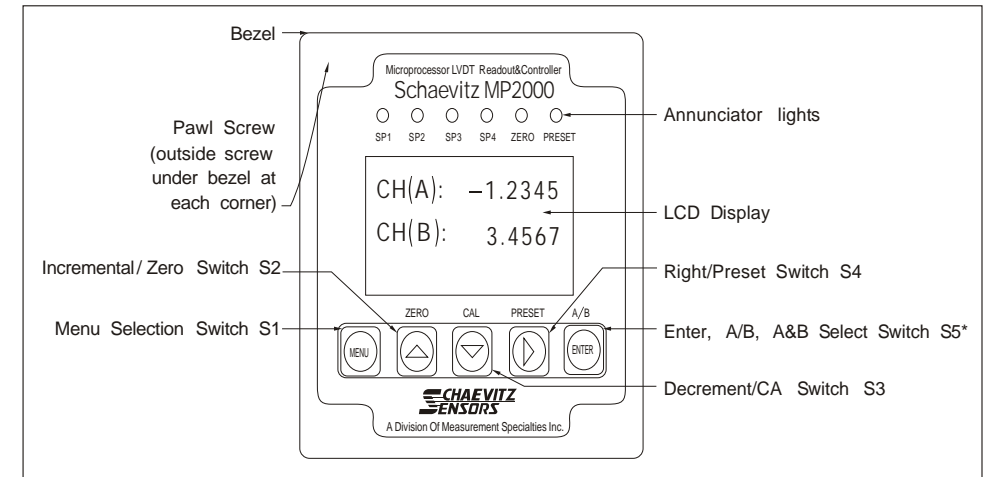

Figure 1. MP2000 Front Panel View

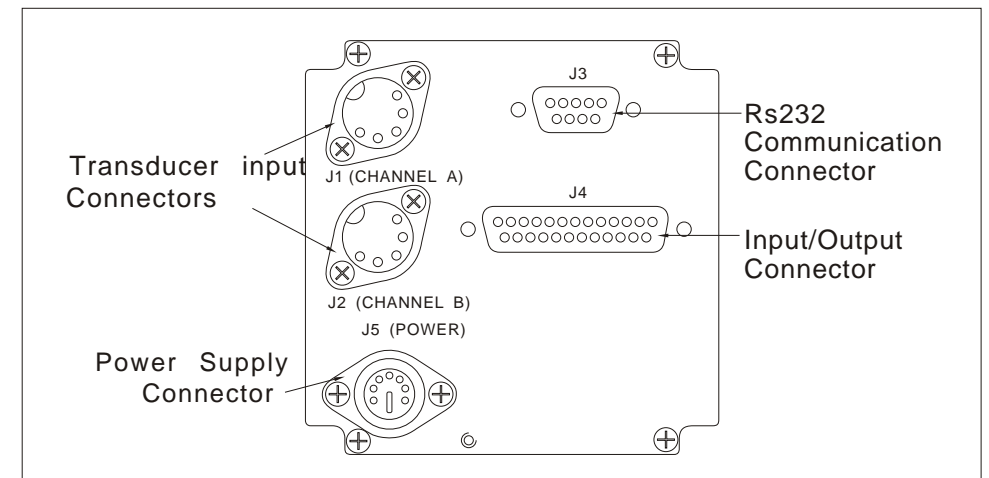

Figure 2. MP2000 Rear Panel View

# Microprocessor-Based LVDT Readout/Controller

## 2. Installation and Wiring

### 2.1 Installation

The MP2000 enclosure is designed for panel mounting in a 1/4 DIN cutout. The cutout dimensions are 3.622 (+0.032, 0.000) inches square. In metric units the cutout is 92 (+0.8, - 0.0) mm square. The mounting system will accommodate any panel thickness between 1/16 inch (1.6 mm) and 1/4 inch (6.35 mm). To panel mount the MP-2000, perform the following steps:

1. Remove the plastic bezel from the front of the unit being careful not to damage it.
2. Rotate the four pawl screws (outside screw in each corner) several turns counter-clockwise to retract the pawls. Make sure the pawls retract enough to clear the back of the mounting panel.
3. Insert the unit into the panel cutout.
4. Position the pawls so that their elongated dimension overlaps the panel cutout; then tighten the screws. Do not over-tighten.
5. Replace the bezel, being careful not to damage it.

### 2.2 Input Power Supply

The power supply provided is designed to operate on input line voltages from 100 to 240 V ac. At 50 to 60 Hz. This device is approved for use in the US, Canada and all European countries, and meets all relevant CE standards, when combined with an approved, country specific, mains power cord.

### 2.3 LVDT Input Wiring

#### 2.3.1 Connections

The transducer inputs, for the MP2000, are 5-pin, DIN style connectors located on the rear panel. See Figure 2.

The instrument is designed for use with 5 or 6 wire LVDT and RVDT type transducers. Best performance is realized when using only five wires in the interconnecting cable. Connect the secondaries at the LVDT and run one wire back to the instrument, as the center tap connection.

### 2.3.2 Wiring

Figures 3 & 4 (Transducer Input Connections) show the proper connections for various types of Schaevitz LVDTs. Connection examples are shown for LVDTs with lead wires and for LVDTs with connectors and both types with and without an extension cable. Extension cables over a few feet long should use shielded, twisted pair construction, as un-shielded wires may be sensitive to radiated EMI and RFI. The shield should be connected to pin 3 or pin 4 on the input connector on the rear panel of the unit or to ground. Primary leads are not as sensitive as the secondary leads, to noise pick up and do not have to be shielded. A cable, such as Belden 8786, with two jointly shielded pairs, inside the center braid and one pair of wires outside, is recommended. The independent pair of unshielded wires should be used for primary connections, and three of the four jointly shielded wires are used for connections to the secondary windings. In

LBB applications, float the shield at the MP end of the cable to avoid ground loops. If the LVDT is located in an extremely noisy environment, the primary leads should be shielded separately from the secondary leads. It is undesirable to have the primary and secondary leads within the same shield as this may cause detrimental coupling between them. If more than one MP2000 is to be used, primary and secondary pairs must be shielded separately, for each LVDT, and attention given to cable dress to prevent heterodyning as a result of unwanted cross talk. If heterodyning problems do occur and cannot be eliminated by shielding and/or physical separation of cables, the carrier signals must be synchronized. See the section on Master/Slave (Synchronized Operation) for further instructions. At excitation frequencies up to 2.5 kHz, many types of AC LVDTs can be operated with cables exceeding 350 feet in length.

# Microprocessor-Based LVDT Readout/Controller

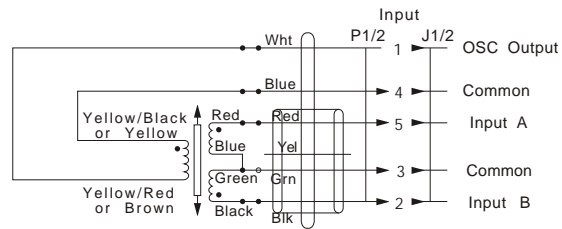

Input Connections-with Cable (LVDT with Leads)

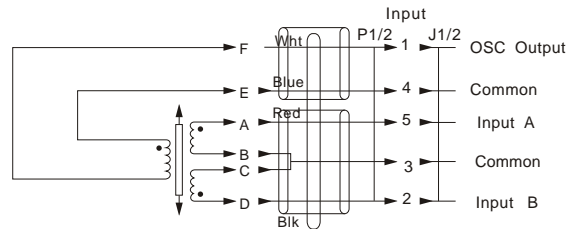

Input Connections-with Cable (LVDT with Connector)

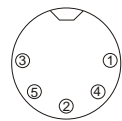

Rear View(Wiring Side) of Transducer Mating Connector

Figure 3. Transducer Input Connections

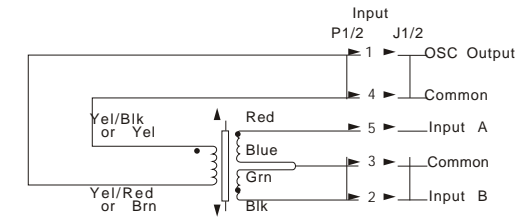

Input Connections-LVDT with Leads

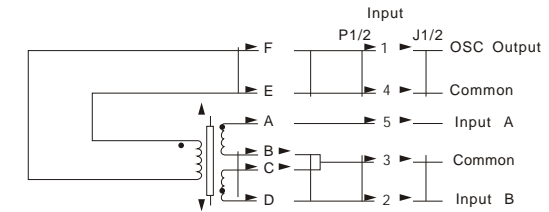

Input Connections-LVDT with Connector

Transducer Series	Connect to Input J1/2	Pin4	Pin1	Pin5	Pin2	Pin3	Pin4	Not Used
LBR315PA-200 PCA-499	Blue	Red	Green	White	Yellow	Shield		
All other LBBs and color-coded LVDTs	Yel/bk or Yel	Yel/red or Brn	Red	Black	Blue & Green			
Letter-coded	E	F	A	D	B&C	H*	G*	
Number-coded	1	2	6	3	4&5			

\* These will not exist on some units

Figure 4. Transducer Input Connections

Note: The maximum usable cable length is transducer dependent and varies with LVDT type, type of cable.

# Microprocessor-Based LVDT Readout/Controller

## 2.4 Output Wiring

### 2.4.1 Output Connections

The I/O connections on the rear panel of MP2000 have both 9-pin and 25-pin connectors, J-3 and J-4).

### 2.4.2 Analog Output (Figure 5, Figure 6)

The MP2000 controller features a Full Scale (from FS to +FS) of +/-5.0 V dc. At the calibrated LVDT/RVDT displacement. The analog output may be over ranged to +/-10.0 V dc. with no degradation in linearity. See figure 5 and Figure 6 for pin-outs.

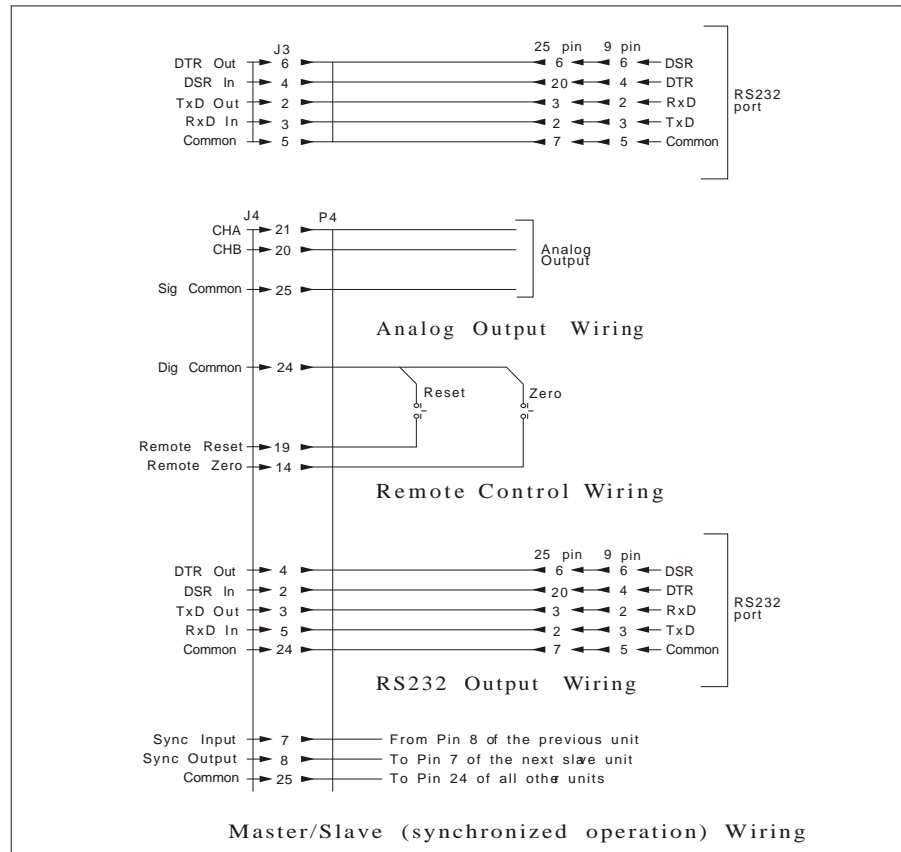

Figure 5. Output Wiring

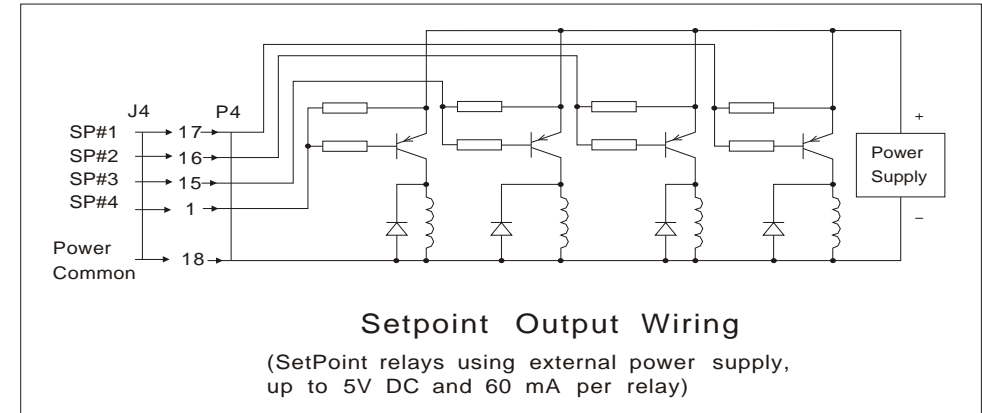

Figure 6. Output Wiring

### 2.4.3 Remote Control

The MP2000 has 2 remote functions. These functions may be hardwire controlled by a remote contact closure such as a PLC output, foot switch or momentary panel mount pushbutton. See figure 5 for pin-out hookup.

#### Remote Zero

Remote zero performs the same function as the "ZERO" button on the front panel. A momentary closure between pins 14 and 24 of the output connector will cause the meter display to zero out, and the zero light to illuminate if the meter had been previously un-zeroed. Zeroing the display with either a remote contact or

the front panel push-button will cause the analog output to go to zero as well. Remote Zero only responds in single line display mode.

#### Remote Reset

Remote reset performs, 1) in two line display mode, clear all the memory of Min/Max/TIR. 2) In single line display mode (e.g. A), clear the memory of Min/Max/TIR except for the Min/Max/TIR only related to another channel ( e.g. Min (B), Max(B), TIR(B)). A front button operation (press [MENU] and [ENTER] together) will perform the similar function. It will clear all the Max/Min/TIR in any condition (except for PROG mode).

## Microprocessor-Based LVDT Readout/Controller

### 2.4.4 Set-point Outputs (Figure 6)

Each set-point has an output to operate external devices, such as relays or PLC digital inputs. These outputs are open-collector, TTL level, capable of driving relays up to 48 V dc and 50 mA per relay. When using an external power supply, connect the relays per Figure 6. Suppression diodes must always be used across relay coils to prevent CEMF spikes from feeding back to the open collectors.

### 2.4.5 RS232 Output (Figure 5)

**RS232 output wiring:**

	<u>9-pin</u>	<u>25-pin</u>
DTR	Pin6	Pin4
DSR	Pin4	Pin2
TXD	Pin2	Pin3
RXD	Pin3	Pin5

The Data Terminal Ready (DTR) line, from the MP2000, is active high when the MP2000 is powered and ready to interact with the computer. It is not necessary for this line to be tied to the computer, if the computer does not require such status to activate the RS232 interface. The DSR line, to the MP2000, must be active high to allow the MP1000/2000 to recognize commands from the computer. This line can be tied active high, at the MP1000/2000, by a connection to the DTR line. The RS232 data is transmitted in 8 sequential bytes, in binary or bit significant format, depending on the parameter. Refer to the section on RS232 Programming later in this manual for information on data format.

## 3. Controls, Adjustments, and Indicators

### 3.1 Setting of LVDT oscillator (Voltage & Frequency)

The drive signal, a digitally generated sine wave for the LVDT, is controlled by soft switches in the menu mode. The voltage and frequency for channel A and B can be separately set through the front panel menu. Drive frequency options are 2.5, 3.3, 5.0, & 10.0 kHz. Drive voltage options are 1 & 3 V(rms).

### 3.2 Sensitivity Setup

The sensitivity may be individually set, for each channel, to either 0.6 V rms, (HI GAIN), or 1.2 V rms (LO GAIN) full scale. See section 4. (Operating Instructions) for details. To achieve proper range and best ADC resolution it is desirable to operate between 60 and 95% of full scale input. Determine the full scale voltage output of the LVDT at the operating frequency for both 1 and 3 volts excitation. Use the excitation and GAIN that allows operation between 60 and 95%. That is 0.36 to 0.57 V rms for HI GAIN or 0.72 to 1.14 V rms for LO GAIN. In selecting the proper excitation make sure that the primary current is less than the rated oscillator current of 25 mA maximum.

The recommended excitation and gain for most Schaevitz LVDTs operating over their full range is given in Table 1.

*Note: The full scale voltage output may be obtained from the individual data sheet or by multiplying the sensitivity of the LVDT by the excitation voltage and the full scale displacement in thousandths of an inch.*

### Examples:

Sens. = 5 mV/V/.001"

FS displacement = 0.100"

Z-pri = 1000 ohms

$5\text{mV/V} \cdot .001" \times 3 \times 100 = 1.5\text{V}$

$5\text{mV/V} \cdot .001" \times 1 \times 100 = 0.5\text{V}$

**Use 1V and HI GAIN (0.6 FS)**

Sens. = 2 mV/V/.001"

FS displacement = 0.050"

Z-pri = 450 ohms

$2\text{mV/V} \cdot .001" \times 3 \times 50 = 0.3\text{V}$

$2\text{mV/V} \cdot .001" \times 1 \times 50 = 0.1\text{V}$

**Use 3V and HI GAIN (0.6 FS)**

Sens. = 0.8 mV/V/.001"

FS displacement = 1"

Z-pri = 220 ohms

$0.8\text{mV/V} \cdot .001" \times 3 \times 1,000 = 2.4\text{V}$

$0.8\text{mV/V} \cdot .001" \times 1 \times 1,000 = 0.8\text{V}$

**Use 1V and LO GAIN (1.2 FS)**

Sens. = 1.2 mV/V/.001"

FS displacement = 0.25"

Z-pri = 80 ohms

$1.2\text{mV/V} \cdot .001" \times 3 \times 250 = 0.9\text{V}$

$1.2\text{mV/V} \cdot .001" \times 1 \times 250 = 0.3\text{V}$

**Use 1V and HI GAIN (0.6 FS)**

**NOTE:** You may not use 3V since the 25 mA rating would be exceeded (3 V / 80 = 37.5 mA)

# Microprocessor-Based LVDT Readout/Controller

**Table A Sensitivity (GAIN) Chart**  
**Recommended Operating Excitation Voltage and Sensitivity Range**

Series	HCA				LBB										
	HR MP	GCA	E	MHR 2.5 kHz	MHR 10 kHz	XS-A	XS-B	XS-C	XS-D	XS-Z -ZTR	LBB STD	Air Extend	Lever Probe	R30A	R36A
0.005				NR	1/HI			NR							
0.010				NR	3/HI			NR						3/HI	3/HI
0.020				NR							3/HI	3/HI	3/HI		
0.025				NR	3/LO										
0.040											3/LO	3/HI			
0.050	3/LO	3/LO		NR	3/HI		NR	3/LO							
0.100	1/HI		3/LO	NR	3/LO		NR			1/HI	1/HI	3/LO			
0.125		3/LO													
0.150								3/LO							
0.200	1/HI		1/HI								1/LO				
0.250		1/HI		NR	1/HI	3/LO	1/HI	1/HI	1/HI						
0.300	1/HI		3/LO												
0.400	3/LO														
0.500	3/LO	1/LO	1/HI	NR	1/LO	3/LO		1/LO	1/HI						
1.000	1/HI	1/LO	1/LO	NR	1/LO	1/HI		1/LO	3/LO	1/HI					
2.000	1/HI	1/LO	1/LO			1/LO	3/LO	1/HI							
3.000	1/LO	1/LO				1/LO		1/HI							
4.000	1/LO														
5.000	1/LO	1/LO	3/LO			1/HI		3/LO							
10.000	1/LO	NR	1/HI					1/HI							
25.000								1/LO							
Freq.	2.5	2.5	2.5	2.5	10	2.5	10	2.5	2.5	2.5	5	5	5	10	2.5

NR = Not recommended

1/HI = 1 V rms Excitation & High GAIN 0.6 V rms FS

1/LO = 1 V rms Excitation & Low GAIN 1.2 V rms FS

3/HI = 3 V rms Excitation & High GAIN 0.6 V rms FS

3/LO = 3 V rms Excitation & Low GAIN 1.2 V rms FS

### 3.3 Front Panel Switches

Refer to Figure 1 (MP2000 Front Panel View) during the following discussion of the front panel switches.

**Warning!**  
 Never Use A Sharp or Pointed Object to Operate the Front-Panel Switches; Serious Damage Could Result

#### 3.3.1 [MENU] select switch (S1)

Return to upper level of Menu, or Exit.

#### 3.3.2 [▲]/ ZERO select switch (S2)

S2 has two functions,  
 1) In PROG mode, press S2 moves the cursor upward, or increase value of the highlighted byte while setting the value of a parameter.  
 2) In RUN mode, when only one channel is displayed, pressing S2 will ZERO the output of the displayed channel. ZERO is performed by obtaining the last reading made prior to initiating the zeroing function and subtracting this value from all subsequent readings.

Press S2 + [ENTER] (S5) together will un-zero the readout and extinguish the ZERO light.

The instrument may be zeroed (tared) anywhere within the specified operating range of the LVDT without affecting the full-scale calibration. If the instrument is zeroed at the maximum retracted position, the LVDT would then effectively have twice its original full-scale range.

Zeroing display will cause analog output to zero as well. Depressing zero at minus full scale will provide 100% zero suppression. That is to say the normally zero centered +/-5 V dc. output will now be zero volts at minus full scale, +5 volts at null and +10 volts at plus full scale.

#### 3.3.3 [▼]/ CAL select switch (S3)

S3 has two functions:  
 1) In PROG mode, pressing S3 moves the cursor downward, or decrease value of the highlighted byte while setting the value.  
 2) In RUN mode, if only one channel is displayed, and if the Cal SW parameter is set to Enabled, pressing S2 will perform a CALIBRATION on the displayed channel.

## Microprocessor-Based LVDT Readout/Controller

Analog Calibration. Performing a digital calibration will automatically scale the analog output to +/-5 V dc. at the +/- calibrated displacement. Calibrating at less than +/- full scale will result in the analog output exceeding the +/-5 volts at the full +/- linear range of the LVDT or RVDT. The analog output may be over ranged to +/-10 V dc. with no adverse effect on linearity.

When MP2000 is rebooted, the Cal SW automatically defaults to Disabled , to prevent an unintended operation of the S3 switch. Channel calibration values are stored in EPROM, and are maintained until next Cal operation occurs.

### 3.3.4 [▶]/PRESET select switch (S4)

Switch S4 has two functions,

1)PROG mode, moves the cursor toward the right, one increment at a time.

2)RUN mode, with one channel on the display, pressing S4 will turn on the pre-set function, for the displayed channel, only.

Pressing S4 momentarily will turn on the preset function. The PRESET light on in front panel will illuminate. Instead of displaying zero after an auto-zero, the readout will display the Preset value previously programmed into the instrument during the PROG operation. The PRESET value is a constant added to, or subtracted from the scaled and zeroed value prior to being displayed. It can be applied to CH(A) or CH(B) readings and is maintained and used for calculating (A+B), (A-B), TIR(A), etc.

### 3.3.5 [ENTER]/ (A/B) select switch (S5)

S5 has two functions, 1) in PROG mode, enter the following menu of selected item. 2) in RUN mode, will switch between single line display of CH(A) or CH(B).

## 4. Operation Instructions

### 4.1 Boot

After you turn on the power, it will take 20 seconds for the system to check the memory. It displays as below, during this process.



### 4.2 Top Level Menu

There are two items here, CHANGE DISPLAY ITEM will allow you pick up to two items to be displayed, while in the dual channel mode. PROGRAM SETTINGS will enter into the PROG mode, of the menu. The VERSION NUMBER of program is 1.0.00. Press MENU to exit current mode and enter into RUN MODE.

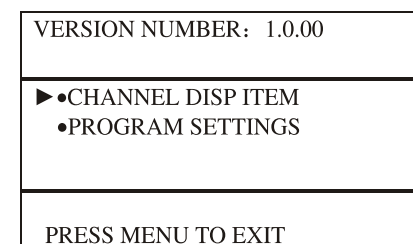

# Microprocessor-Based LVDT Readout/Controller

## 4.3 RUN mode

Select CHANGE DISPLAY ITEMS, Select one item, press [ENTER], will go to, press [ENTER], will go to,

```

▶ • TOP LINE
  • BOTTOM LINE

>TOP>CHANGE>ITEM
    
```

```

▶ A      MAX:A+B   TIR:B
  B      MIN:A+B   MAX:A
 A+B     MAX:A-B   MIN:A
 A-B     MIN:A-B   MAX:B
          TIR:A    MIN:B
    
```

Use [▼],[▲],[▶] to select, press [MENU] Exit.

```

CH(A):  +123.45
CH(B):  -567.89
    
```

Once the actual value is over the full scale value set up, the symbol FS will display  
In RUN mode, display will automatically show two items.

```

CH(A):  +123.45

CH(B)FS: -867.89
    
```

Pressing [ENTER] will go to the one channel display mode. Pressing [ENTER] again will switch between CH(A) and CH(B).

```

CH(A):  35.23
    
```

- Operation of the [▲] button will zero the displayed channel, Press [▲] + [ENTER] together will cancel the zero and resume the original value.
- Operation of the [▼] button will invoke the calibration function. If set up the CALIBRATION SWITCH to be enable in PROGRAM SETTINGS mode
- Operation of [▶] will turn on or turn off the pre-set function.

Pressing [MENU] will return you to the two-items display mode.

## 4.4 VOLTMETER FUNCTION

Press [▼]+ [ENTER] in the condition of displaying CH(A) or CH(B) individually (set up CALIBRATION SWITCH to DISABLE CAL IN RUN MODE), will enter into VOLTMETER FUNCTION.

```

          ADC INPUT
          1V  2.5KHZ  LOW GAIN

          0.8807 V  CH(A)

          ANY BUTTON TO EXIT
    
```

# Microprocessor-Based LVDT Readout/Controller

## 4.5 PROG MODE

After select PROGRAM SETTINGS, system will ask for password to go into PROG mode. The password is [▲][▼][▶][▼]. If entered incorrectly, after four key strokes, the system will ask for password again. After four incorrect attempts, the system will exit and return to the upper level.

Following password input, will be,

- ▶ • CH(A) SETTING
  - CH(B) SETTING
  - CALIBRATION SWITCH
  - SP SETTING
  - OSC CHOICE
  - RS232 SETTING
- >PROG>

Select item CH(A) SETTING will go to,

- ▶ • DECIMAL POINT
  - PRESET VALUE
  - CALIBRATION VALUE
  - FUL SCALE
  - GAIN
- >PROG>CH(A) SETTING>

Note: Pressing [ENTER] will usually go to the menu of the selected item. When you are working at the lowest menu level of the item branch, pressing [ENTER] will be the same as [MENU], returning back to upper level.

Use [▶] to move the cursor.

CH(A) decimal point setting.

DECIMAL POINT SETTING  
CH(A): 000.00

CH(A) preset setting.

PRESET SETTING  
CH(A): 000.00

CH(A) Calibration Value setting

CAL VALUE SETTING  
CH(A): 000.00

CH(A) full scale setting

FULL SCALE SETTING  
CH(A): 100.00

CH(A) Gain setting

- ▶ • GAIN LOW
- GAIN HIGH

>CH(A) SETTING>GAIN>

CALIBRATION SWITCH

- ▶ • DISABLE
- ENABLE

CAL IN RUN MODE

>PROG>CALIBRATE SW>

**CH(B) settings are the same as CH(A).**

SP SETTING

- ▶ • SP1
- SP2
- SP3
- SP4
- HVSTERESIS SETTING

>PROG>SP SETTING>

SP1 MONITOR PARAMETER SETTING.

- ▶ • MONITERED OBJECT
- TRIGGER MODE
- VALUE

A HIGH 050.00

>PROG>SP SETTING>SP1

# Microprocessor-Based LVDT Readout/Controller

SP1 monitored object setting.

```

▶ A   MAX:A+B   TIR:B
  B   MIN:A+B   MAX:A
A+B   MAX:A-B   MIN:A
A-B   MIN:A-B   MAX:B
      TIR:A     MIN:B
    
```

SP1 trigger mode of monitored object.

```

▶ • LOW
  • HIGH

SP1>TRIGGER MODE
    
```

SP1 monitor val setting.

```

MONITOR VAL SETTING

SP1      100.00
    
```

Setting Hysteresis Value

```

▶ • LOW
  • HIGH

>SP>HYSTERESIS SET>
    
```

**Menu of SP2-SP4 is the same as SP1**

Pressing [ENTER], Will

```

HYS  VALUE

LOW      05.000
    
```

OSC choice

```

▶ • OSC SOURCE
  • OSC FREQUENCY
  • OSC VOLT CH(A)
  • OSC VOLT CH(B)

>PROG>OSC CHOICE>
    
```

OSC internal and external choice

```

▶ • OSC INTERNAL
  • OSC EXTERNAL

>PROG>OSCCHOICE>OSC SOURCE
    
```

OSC frequency choice

```

▶ • 2.5 KHZ
  • 3.3 KHZ
  • 5.0 KHZ
  • 10.0 KHZ

>PROG> OSC> OSC  FREQ>
    
```

CH(A) OSC voltage rang setting

```

▶ • 1 V
  • 3 V

>OSC >OSC VOLT CH(A)
    
```

Setting RS-232 Baud rate

```

• 1200
• 2400
• 4800
▶ • 9600
  • 19200

>PROG>RS232 SETTING
    
```

## Microprocessor-Based LVDT Readout/Controller

### 5. Calibration Instructions

**Step 1.** Determine LVDT Sensitivity: Find the sensitivity of your LVDT by referring to the calibration sheet accompanying your unit, or by checking the catalog specification for your specific model. Sensitivity is expressed in  $mV/V/.001"$ . (millivolt of output, per volt of excitation, per .001 inch of displacement from null "0" position).

**Note:** LVDT sensitivity will change with excitation frequency.

**Step 2.** Determine Full Scale LVDT output: Perform two calculations.

1. Multiply the sensitivity X 1 V rms X the full scale displacement (in thousandths of an inch).

2. Multiply the sensitivity X 3 V rms X the full scale displacement (in thousandths of an inch).

*Example: If using a Schaevitz LBB-100 gage head with sensitivity of 5.0 mV/V/.001" (at 5kHz) and full scale displacement of 0.100":*  
Calculation #1.  $5 \times 1 \times 100 = 5 \times 100 = 500 \text{ mV}$   
Calculation #2.  $5 \times 3 \times 100 = 15 \times 100 = 1500 \text{ mV}$

**Step 3.** Full Scale Meter Sensitivity: Use the full scale LVDT output that is the closest number of the full scale sensitivity of the meter without

exceeding it. (600mV in high gain or 1200mV in low gain). Since calculation #2 in our example results in a full scale output that exceeds the low gain (1200mV) sensitivity of the meter, calculation #1 must be used for the set up.

**Step 4.** Set the drive frequency, drive voltage, and gain.

From Table 1, you get the drive frequency of LBB-100 is 5kHz. Then you can go to PROG mode (>PROG> OSC CHOICE>OSC FREQUENCY>) to select 5kHz. (Press [Enter] to exit) To decide the drive voltage and gain, like *Calculation #1*, we select like this, 1) if the value is close to 600mV (0.36 0.57Vrms), select gain HIGH. 2) if the value is close to 1200mV (0.72 1.14 V rms.), select gain LOW.

**Step 5:** Plug LVDT into meter, turn on power, and warm up for approximately 10 minutes.

**Step 6:** Set the CALIBRATION SWITCH to enabled.

**Step 7:** Set the DECIMAL PT. This can be done at a path of >PROG>CH(A) SETTING>

**Step 8:** Set the PRESET. This can be done at a path of >PROG>CH(A) SETTING>

**Step 9:** Set the CAL VALUE. The CAL VALUE or calibration displacement is the distance the transducer will be moved during calibration. It is the reading desired in engineering units with the calibration displacement applied. This

operation must be performed using a gage block, shim of known value, micrometer, or other method of precise displacement. Enter the CAL VALUE in engineering units. (inches, millimeters, etc.). Using the right arrow button, move the cursor block one space at a time to the right, incrementing with the up arrow, or decrementing with the down arrow, each number as you go.

Depress the [MENU] button when finished to save the entry. Repeat this process on channel B, for the MP2000 operation.

**Step 10:** Set the FULL SCALE.

This number is the displacement for which the transducer is rated, not the range over which it is being used. It is used to keep track of the transducer's position relative to the electrical zero (null) of the LVDT when you use the auto zero button to off-set the meter zero. Exceeding this value will result in a greater than FS indication.

You are now ready to calibrate channel A.

First, you will need to position the LVDT in its mid-point, (zero output position). A built-in multi-meter function will help you to quickly locate the null, mid-point. Press [CAL] and [ENTER] together. The meter will enter the voltage mode, and will display the net ADC input as a Voltage.

**Step 11:** the calibration procedure.

In RUN mode, press [ENTER] to go into the one-channel display mode, press [ENTER] again to toggle between CH(A) and CH(B), press [▼] (CAL) will go into the calibration menu.

FULL SCALE : 100.00  
CAL VALUE : 40.000

PLEASE MOVE SENSOR TO  
MIDDLE POINT  
>>ENTER TO CONFIRM

## Microprocessor-Based LVDT Readout/Controller

Next, press [ENTER], this will be taken as the first point of calibration. The LVDT null may not be exactly the mechanical center point of the sensor, but it will be close. be sure that the LVDT does not exceed the FULL SCALE setting, during the next step.

FULL SCALE : 100.00  
CAL VALUE : 40.000

PLEASE MOVE SENSOR TO  
END POINT  
>>ENTER TO CONFIRM

Displace the sensor the exact distance, as defined by CAL VALUE , in a positive direction, (toward the leads). Press [ENTER] and this will be taken as the second point of the calibration.

CALIBRATION OK

PRESS ANY KEY TO EXIT

Press any key to exit. The calibration process of the selected channel is completed.

**Step 12:** Repeat process for channel B.

## 6. RS232 OUTPUT

### 6.1 General

See section 2.4.5 RS232 Output for RS232 connections and wiring. This section also discusses the DTR and DSR lines. The data is transmitted in the following format:

One Start Bit;  
Eight Data Bits;  
No Parity, Bit;  
One Stop Bit

The RS232 port is active only in the two-line display status of RUN mode and will not respond in the PROG mode, or one-channel display status of RUN mode.

MP2000 can be changed into PROG mode by front panel operation. So, a strong RS232 control is required to Lock MP2000 keyboard after connected successfully, and do hand-shaking periodically to firm the keyboard Lock.

The demo Visual Basic program demonstrates the details we will discuss below. Please refer to the demo for the communication procedures, data format, data check method, hand shaking, etc.

### 6.2 RS232 Baud Rate Setting.

The RS232 Baud Rate can be set in the PROG mode. Please refer to the manual. The baud rate settings available, are as follows:

Rate  
1200  
2400  
4800  
9600  
19200

The baud rate is updated at the time of the change, in PROG mode.

### 6.3 RS232 Procedures.

#### 6.3.1. Baud Rate auto-detection, or hand-shaking.

MP2000 has built-in response. When it receives a byte 0x80, it will send byte 0x80 in return.

This can be used in two places,  
1) Baud Rate auto-detection. If PC sends 0x80 and gets 0x80 back, it means PC is using the correct Baud rate.

2) Hand-shaking. When MP2000 keyboard is set Locked by the PC, PC must periodically send this byte 0x80 for hand-shaking purpose.

Otherwise, MP2000 will unlock its keyboard automatically after it has been missing 0x80 for continuously (about) 30 seconds. MP2000 does this to insure that RS232 is still connected.

#### 6.3.2. Commands.

Commands from PC to MP2000 are using the same format,  
Command ID + Command String + Verify Byte + 0x0d

0x0d is the END byte for every Command.

When PC sends commands to MP2000, the PC will wait for the response. If PC does not receive the correct answer, or no response within 1-second, the PC will repeat the last-sent command, until the correct response is received.

Below is detailed explanation of the communications format.6.3.2.1. Command ID.

## Microprocessor-Based LVDT Readout/Controller

Command ID	Function	Send out format
0x50	Preset Value of CHA	nnnnnnn (see 6.4.6)
0x51	Preset Value of CHB	nnnnnnn (see 6.4.6)
0x52	Zero-ed Value of CHA	nnnnnnn (see 6.4.6)
0x53	Zero-ed Value of CHB	nnnnnnn (see 6.4.6)
0x54	Full Scale Value of CHA	nnnnnnn (see 6.4.6)
0x55	Full Scale Value of CHB	nnnnnnn (see 6.4.6)
0x60	Object to be monitored by SP1	n (See 6.4.1)
0x56	The value of SP1	nnnnnnn (see 6.4.6)
0x61	Object to be monitored by SP2	n (See 6.4.1)
0x57	The value of SP2	nnnnnnn (see 6.4.6)
0x62	Object to be monitored by SP3	n (See 6.4.1)
0x58	The value of SP3	nnnnnnn (see 6.4.6)
0x63	Object to be monitored by SP4	n (See 6.4.1)
0x59	The value of SP4	nnnnnnn (see 6.4.6)
0x65	The SP1-4 TRIG MODE	n (See 6.4.8)
0x64	CH A,B Gain, Voltage	n (See 6.4.5)
0x66	Decimal Point of CH A	n (See 6.4.2)
0x67	Decimal Point of CH B	n (See 6.4.2)
0x6d	Hys value for trig-high SP's	nnnnnnn (See 6.4.6)
0x6c	Hys value for trig-low SP's	nnnnnnn (See 6.4.6)
0x68	Osc frequency	n (See 6.4.4)
0x69	Communication Baud Rate	n (See 6.4.3)
0x6e	Top line display item	n (See 6.4.1)
0x6f	Bottom line display item	n (See 6.4.1)
0x6b	Osc source and CAL Switch	n (See 6.4.9)
0x46	CH A Calibration Factor	nnnnnnn(See 6.4.11)
0x47	CH B Calibration Factor	nnnnnnn(See 6.4.11)
0x48	CH A Preset/Zero enable/disable	n(See 6.4.12)
0x49	CH B Preset/Zero enable/disable	n(See 6.4.12)
0x78	MP Keyboard and Data-Update Byte	n(See 6.4.7)
0x79	CH A or B Reset	n(See 6.4.13)

### 6.3.2.2. Command String

This has 2 conditions,

1) When the PC reads MP2000 setting, it is a fixed byte, 0x7f In this case, PC is expected to get the MP2000 Value of the item represented by the sent Command ID, in a format of, Command ID + Data String + Verify Byte + 0x0din which Data String is using the same format as Command String (see table above).

In case of an error, the PC will repeat the last-sent Command as many times as necessary.

2) When changing MP2000 settings, with a PC, see the above command ID table for data formats.

The PC is expecting the MP2000 to send back the Command ID, in the following format, *Command ID + 0x0d*, to confirm that a successful change was made. If no response is received, you must repeat the last-sent command. Failure to verify the correct meter status, may cause an unknown MP2000 configuration.

### 6.3.2.3. Verify Byte

This byte is a result of byte calculation of the bytes before this Verify Byte, which includes Commands ID and Commands String bytes.

Its value = ( - sum of bytes + 1) mod 128, A result of 0x0d, will be an actual value of 0x0c (subtract 1).

### 6.3.2.4. 0x0d

These bytes appear at the end of a complete RS232 communication string only.

### 6.3.3. 300ms-Data-Update Procedure.

When MP2000 is in its normal two-line display status, if it is required by remote PC to START this procedure, it will send the values of the two display items, and the SP status to RS232 port, about every 300ms if not disturbed by other operation.

To START or CLOSE the procedure, see 6.3.2 and 6.4.7.

## Microprocessor-Based LVDT Readout/Controller

The RS232 data is transmitted in 19 sequential bytes, in Text format.

### Byte Description

1-7	Obj1 Value	(ASCII STRING)	7BYTES (see 6.4.6)
8-14	Obj2 Value	(ASCII STRING)	7BYTES (see 6.4.6)
15	SP Byte	(ASCII CODE)	1BYTE (see 6.4.10)
16	Verify Byte	(ASCII CODE)	1BYTE (see 6.3.2.3)
17	0x0d		

### 6.4. Data Format

#### 6.4.1. “n” , a hex Byte for MP2000 Menu display items

n	Function	n	Function	n	Function
0x30	Channel A	0x35	MIN(A+B)	0x3a	MAX A
0x31	Channel B	0x36	MAX(A-B)	0x3b	MIN A
0x32	A + B	0x37	MIN(A-B)	0x3c	MAX B
0x33	A B	0x38	TIR A	0x3d	MIN B
0x34	MAX (A+B)	0x39	TIR B		

#### 6.4.2. “n” , a hex Byte for Decimal Point.

The decimal point position is represented as,

The value for .xxxxx is 0x30

The value for x.xxxx is 0x31

The value for xx.xxx is 0x32

The value for xxx.xx is 0x33

The value for xxxx.x is 0x34

The value for xxxxx. is 0x35

#### 6.4.3. “n” , a Byte for Baud Rate.

The baud rate settings are as follows:

Rate	n
1200	0x30
2400	0x31
4800	0x32
9600	0x33
19200	0x34

#### 6.4.4. “n” , a Byte for Osc. Frequency:

Osc. Frequency	n
2.5 KHZ	0x30
3.3 KHZ	0x31
5.0 KHZ	0x32
10.0 KHZ	0x33

#### 6.4.5. “n” , a Byte for Channel A,B Gain and excitation voltage, which 8-bits are, 0/0/1/1/v-B-bit/v-A-bit/g-B-bit/g-A-bit

For v-B-bit, 1 stands for channel B excitation voltage is 3V, 0 for 1V.  
 For v-A-bit, 1 stands for channel A excitation voltage is 3V, 0 for 1V.  
 For g-B-bit, 1 stands for channel B Gain High, 0 for Gain Low.  
 For g-A-bit, 1 stands for channel A Gain High, 0 for Gain Low.

#### 6.4.6. “nnnnnnn” , string format for “Double”

MUST be in 7 ASCII Bytes, in a format of,

+/- x x x . x x

in which the position of . may vary depending on what value you are sending from 99999. to +.00001 to +99999. .

#### 6.4.7. “n” , a Byte for Lock/Unlock MP2000 keyboard, telling MP2000 to Update/Do-Not-Update its normal display items to PC. Its 8-bits are,

0/0/1/1/0/0/Keyboard-bit/Data-Update-bit

For Keyboard-bit, 1 stands for Lock the MP2000 keyboard. 0 for Unlock.

For Data-Update-bit, 1 stands for set MP2000 to START the 300ms-Data-Update procedure, 0 for CLOSE.

#### 6.4.8. “n” , a Byte for Trig Mode setting, which 8-bits are,

0/0/1/1/SP1-trig-bit/SP2-trig-bit/SP3-trig-bit/SP4-trig-bit

For every SPx-trig-bit, 0 stands for trig low , 1 for trig low .

#### 6.4.9. “n” , a Byte for Osc. Source and CAL Switch setting, which 8-bits are,

0/0/1/1/0/0/CAL-bit/OscS-bit

For CAL-bit, 0 stands for CAL Switch Disabled, 1 for Enabled.

For OscS-bit, 0 stands for Osc Source External, 1 for Internal.

#### 6.4.10. SP Byte, a Byte which 8-bits are,

0/0/1/1/SP4-bit/SP3-bit/SP2-bit/SP1-bit

For each SPx-bit, 0 stands for Triggered, 1 for No-Trigger.

## Microprocessor-Based LVDT Readout/Controller

**6.4.11 Calibration Factor data format. It includes 7 bytes, B1/B2/X/X/X/X/X,** in which, B1, is for + or -. B2, and X are positive integers. The value it stand for is,  $X.XXXX * 10 ^ \wedge (B1B2)$

For example,  
-212345 stands for  $1.2345 * 10 ^ \wedge (-2) = 0.012345$   
+3.12345 stands for  $1.2345 * 10 ^ \wedge (+3) = 1234.5$

**6.4.12 Preset/Zero Enable/Disable Byte.** Its 8-bits are, 0 / 0 / 1 / 1 / Zero Disable / Preset Disable / Zero Enable / Preset Enable. For the function bits above, 1 for set MP2000, 0 for No Operation.

**6.4.13 CH A or B Reset Byte. Its 8-bits are,** 0 / 0 / 1 / 1 / 0 / 0 / CHB Reset / CHA Reset. For the function bits above, 1 for set MP2000, 0 for No Operation.

## 7. Glossary

### • CAL VALUE

A number used by the microprocessor as the value to be displayed when the CAL switch is depressed during calibration. Used as one point of a straight line, along with the zero point, when calculating the slope.

### • FULL SCALE

A scaled number, when exceeded, will cause the readout to display "Out of FS." This display is meant to alert the user that he may be beyond the linear range of the LVDT

### • Hysteresis

These are two absolute value numbers that are added to or subtracted from the set-point values only when the set-points are on or activated. The High Hysteresis value is subtracted from the high set-point values and compared to the scaled reading. If the scaled reading is less than this value, the high set-point is deactivated. The Low Hysteresis value is added to the low set-point values and compared to the scaled reading. If the scaled reading exceeds this value, the low set-point is deactivated.

### • Open Collector

This is a type of digital TTL output. It consists of an output from the collector of a transistor without a collector resistor known as a "pull-up" resistor, and whose emitter is tied to common. Normally, the output is floating. When the transistor is turned on, the output is tied to common. It may be thought of as a normally open switch connected from the output line to common.

### Pre-set Number (Pre-set Value)

A constant that is added to or subtracted from the pre-scaled and zeroed reading. Normally used to enter a fixed value to delta measurements in order to display the full dimension. Set-points (SP1 thru SP4) These are four programmed values which are constantly compared, at the update rate of the instrument, to the scaled reading on the display. A high set-point triggers when the scaled reading exceeds the set-point value. The open collector output for the activated set-point will turn on (low) and corresponding front panel annunciator will illuminate. If the displayed readings equals or is less than the set-point value, nothing will happen. If the set-point value is exceeded, the incoming data must then drop below the set-point value less the High Hysteresis value before the output deactivates and the annunciator turns off. A low set-point activates when the scaled reading is less than the set-point value. The open collector output for the activated set-point will turn on (low) and the corresponding front panel annunciator will illuminate. If the displayed reading equals or exceeds the set-point value, nothing will happen. If the displayed reading drops below the set-point value, it must then exceed the set-point value plus the Low Hysteresis value before the output deactivates and the annunciator turns off.

### Error Codes

MP2000 may generate some warnings if you perform an improper operation or a wrong setting input. Here is a list of all the warning codes and their references.

## Microprocessor-Based LVDT Readout/Controller

Warning Code	Description
1	Calibration Switch disabled
2	Cal Number invalid, must >0 and <99999.0
3	Cal Number a error, must >0 and <99999.0
4	Cal Number b error, must >0 and <99999.0
5	FS A error, must >0 and <99999.0
6	FS B error, must >0 and <99999.0
7	SP1 value error, must >-99999.0 and <99999.0
8	SP2 value error, must >-99999.0 and <99999.0
9	SP3 value error, must >-99999.0 and <99999.0
10	SP4 value error, must >-99999.0 and <99999.0
11	Preset A error, must >-99999.0 and <99999.0
12	Preset B error, must >-99999.0 and <99999.0
13	Zero A error, must >-99999.0 and <99999.0
14	Zero B error, must >-99999.0 and <99999.0
15	CH A Calibration Factor error, must >0
16	CH B Calibration Factor error, must >0
17	SP1 object error, value must <=13, only 14 kinds of choice
18	SP2 object error, value must <=13
19	SP3 object error, value must <=13
20	SP4 object error, value must <=13
21	Decimal Point A error, must <=5, only 6 kinds of status
22	Decimal Point B error, must <=5
23	Osc Frequency error, value must <=3
24	Preset/Zero error (cha and chb zero, preset status is uncertain)
25	Hys Low value error, must >-99999.0 and <99999.0
26	Hys High value error, must >-99999.0 and <99999.0
27	Object of top line display is wrong, value must <=13
28	Object of bottom line display is wrong, value must <=13
29	Baud Rate error, value must <=4, only 5 kinds of choice
30	Will restore MP2000 to factory setting
31	When displacement is exceed 2FS range, Zero function will be disable

### Multi-meter

We have a build-in Multi-meter function telling the net voltage input into the ADC. Gain to LVDT differential input is 2.16 (gain low) and 4.32 (gain high). It looks like,

```

ADC INPUT
1V 2.5KHZ LOW GAIN

-1.5374 v CH(A)

ANY BUTTON TO EXIT
    
```

In single line display mode, press [CAL] and [ENTER] together, will get into the Multi-meter mode.

# Distribuidor

Brasil e América do Sul

## CONTATO

### Endereço

Rua Sete de Setembro, 2671 - Centro  
13560-181 - São Carlos - SP - Brasil

### Telefone

+55 (16) 3371-0112

### Fax

+55 (16) 3372-7800

### Internet

[www.metrolog.net](http://www.metrolog.net)  
[metrolog@metrolog.net](mailto:metrolog@metrolog.net)



Metrolog Controles de Medição