



# IMPORTANT NOTICE

The IEM 422 LVDT signal conditioner module is a line-powered LVDT Position transmitter system. AC Line voltage is supplied to the PSD 4-15 power supply, which provides 30 Volts dc to the LDM- signal conditioner.

The LDM module supplies AC sine wave excitation to the LVDT and demodulates and amplifies the LVDT output. The module consists of a carrier oscillator, AC amplifier, demodulator, filter and DC amplifier. The LVDT excitation frequency is factory pre-set to 2.5 kHz.

A 5 and 10 kHz, excitation is available by use of internal DIPswitches. The factory default setting for LVDT drive is 3 Volts RMS. An internal switch may be used to select 1 Volt rms. drive, for LVDTs with low primary impedance or full scale outputs exceeding the maximum FSO on the page 9 gain table.

Seven gain ranges are available to provide position output signals of  $\pm 5$ Vdc, 0-5Vdc or 0-10Volts DC., for LVDT full-scale signals ranging from 50 mV. RMS. to 2.5 Volts RMS. Gain and output ranges are selectable by internal DIP switches. A span trimmer potentiometer is provided for precise control within each gain stage. Internally selectable master/slave function allows synchronization of multiple IEM-422 modules to prevent beat frequencies and cross talk between transducers.

A zero trimmer potentiometer provides fine correction for zero offsets.

The IEM-422 module operates with all Schaevitz 5 or 6 lead LVDTs and RVDTs.

## Specifications

<b>Power Requirements:</b>	115 VAC $\pm$ 10% / 230 VAC $\pm$ 10% @ 47 to 63 Hz
<b>Transducer Excitation:</b>	3 or 1 Volt rms.
<b>Drive Current:</b>	25mA max
<b>LVDT Input Impedance (min):</b>	120 $\Omega$ (at 3.0 V rms. excitation) 500 (at 1.0 V rms. excitation)
<b>Excitation Frequency:</b>	2.5, 5.0 or 10.0 kHz. (switch selectable)
<b>Full Span Output Signal:</b>	4 to 20 mA
<b>Zero Point:</b>	12 mA
<b>Zero Adjustment Range:</b>	+/- 30% full range
<b>Frequency Response:</b>	3dB @250 or 1000Hz
<b>Non-linearity:</b>	$\leq$ 02% FS
<b>Temperature Coefficient :</b>	$<\pm .02\%$ per degree F ( $<\pm .04\%$ per degree C)

Operating Temperature:

- 25 to + 70 degrees C

### Enclosure Dimensions

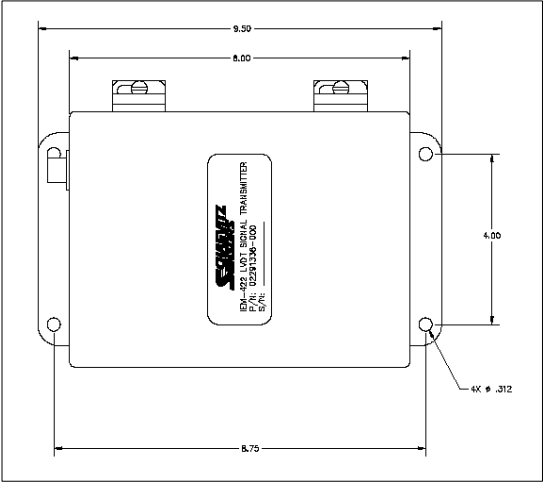

Front View

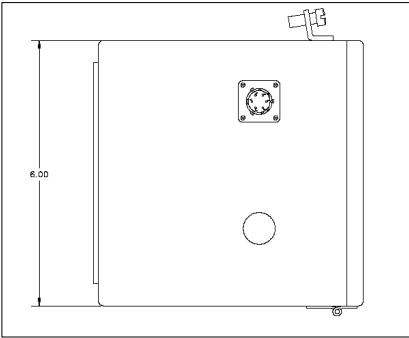

Top View

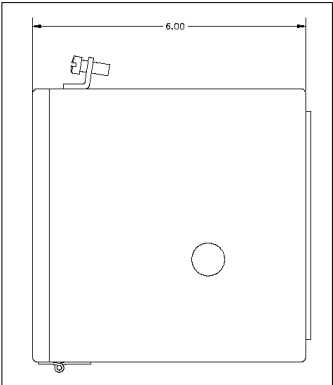

Bottom View

## Controls, Adjustments and Indicators

### Front Panel Controls

**Span:** Sets the 4 and 20 mA positions.

**Phase:** Optimizes amplifier demodulation to compensate for cable or LVDT induced phase shift.

**Zero:** Sets the 12 mA position.

### Front Panel Indicators

**Pwr. LED:** Indicates when DC power is applied.

**Loop LED:** Indicates when loop current is flowing. LED intensity is proportional to the amplitude of the signal.

### IEM-422 External Wiring

To power the IEM-422, connect the negative wire to the 'ZERO' terminal of the power supply module, connect the positive 'live' wire to the positive "+" terminal of the internal fuse block.

Connecting the LVDT is done through the flange-mounted connector on the top of the IEM-422. The LVDT must be attached to the appropriate mating connector, Schaevitz part number 62101056-000, as shown.

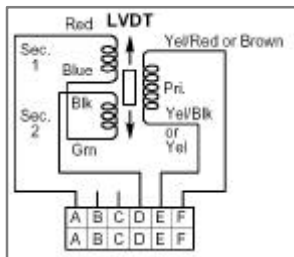
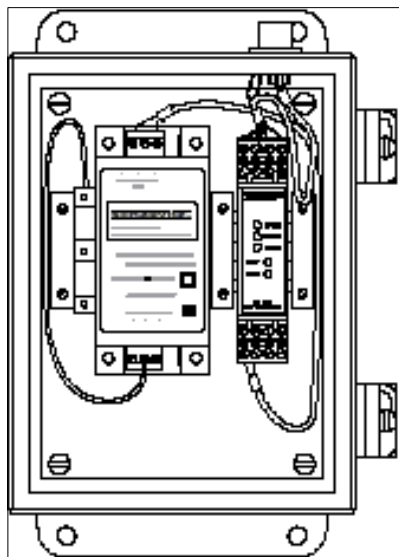

In order to configure the IEM 422 you must access the internal dip switches on the signal conditioning module. You can remove the LDM module, if necessary, by unlatching it from the DIN rail, with a small screwdriver, on the metal retaining clamp. The LDM-1000 module will then lift off of the rail.

The front panel of the conditioning module may be slid out to gain access. To open the housing, depress the two latches, (see photos below), with a screwdriver, the housing will spring open. You can now slide the front panel and board assembly forward to access the dip switches and input voltage jumper.

After approximately 4 cm of extension, a spring stop will prevent the PCB from being removed completely and, will lock it in place. The module may be configured easily from this position.

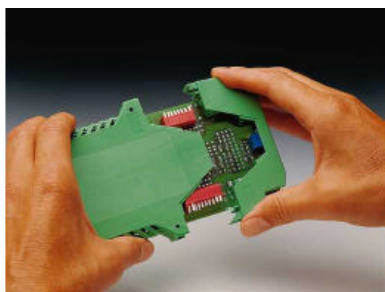
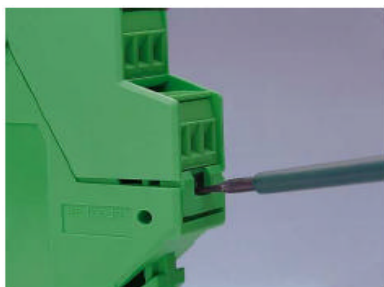

### LDM-1000 Internal Switches

There are two internal dip switch sets on the LDM -1000 LVDT signal conditioner. The tables below explain the switch positions and functions.

Switch SW-1									
Switch Number	1	2	3	4	5	6	7	8	
Function	Offset		Signal Bandwidth			Gain 2	Gain 1		
On	Pos	Neg	1000 Hz	1000 Hz	1000 Hz	Low			
Off	Off	Off	250 Hz	250 Hz	250 Hz	High			
X4.43			All Switches Must Be					On	On
X3.63			In The Same Position					On	Off
X1.2							Off	On	
X0.4							Off	Off	

Switch SW-2								
Switch Number	1	2	3	4	5	6	7	8
Function	Osc Freq		Sync	Osc. V	None	Desired Output (V-dc)		
On			INT	1 V	NOT	0 to 5	+ 5	0 to 10
Off			EXT	3 V	USED	Only One On		
10 kHz	On	On				4 to 20 Works With Any Setting		
5 kHz	Off	On						
2.5 kHz	Off	Off						

### Internal Wiring

The input/output connectors are four position, indexed, plug-in screw terminal barrier strips. Once all of the connections are made, the LDM-1000 conditioner module may be removed and reinstalled without disconnecting the individual wires. The wire clamps are designed to accept AWG-24 to AWG-12 sized stripped and tinned wires with no soldering required.

### Internal Input

The primary and secondary leads of the LVDT connect to P-1. The cable shields, connect to P-2. The LDM-1000 is a four-wire LVDT signal conditioner and does not require connection of the center tap to the input connector. The center tap wires, usually blue and green, of six wire LVDTs must be connected together. For best performance, center taps should always be connected as close to the transducer as possible. Twisted, separate shielded, two pair cable such as Belden 8723 or equivalent is recommended for the LVDT input wiring.

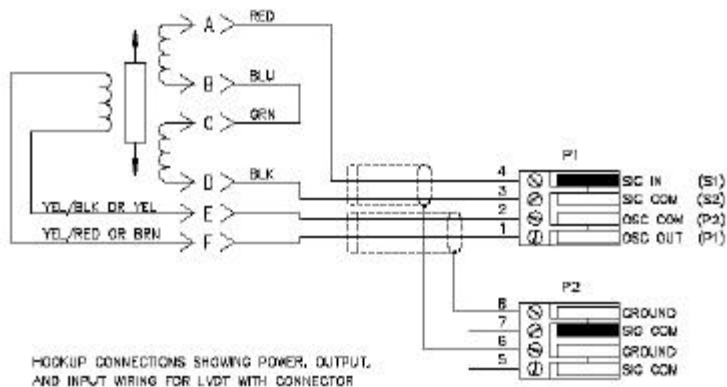

### Outputs

The voltage output position signal is wired to P3. The 4-20 mA current position signal is wired to P4, see fig 2.

### Power

Internal power is provided by the PSD4-15 power supply module. The input power, to operate the LDM-1000, is wired to P4, see fig 2.

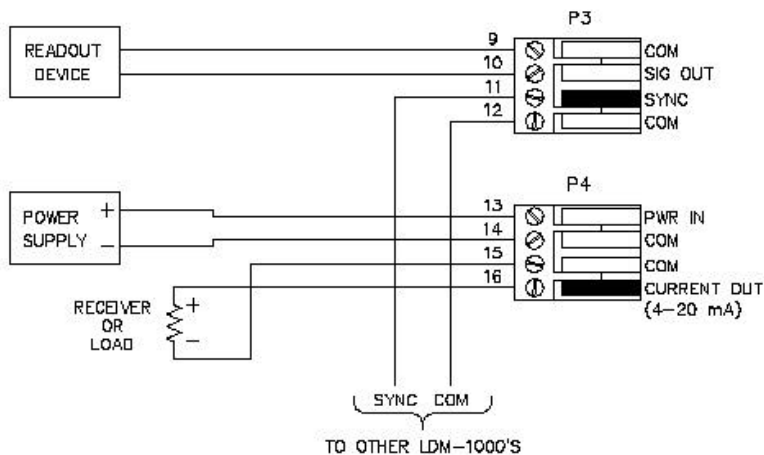

### Master/Slave Wiring

To synchronize the carrier frequencies of two or more instruments, pin 11 and 12, of the master, should be tied to 11 and 12 of each slave. SW2-3, must be placed in the on or INT position, on the instrument selected as the master. All of the LDM-1000 slaves must have SW2-3 in the off or EXT position.

**Caution:** Connecting the Sync terminal, pin 11 of P3, of two units with INT sync selected (SW2-3 on) may result in damage to the units, see fig 2.

### General

For outside installations or cable lengths greater than 30m external surge suppression should be provided by the end user to ensure continued compliance with EMC directives.

## Oscillator Voltage Selection

The default setting as shipped for the oscillator voltage is 3V. The maximum oscillator output current is 25 mA. rms. Thus for the 3 V oscillator output, the minimum load impedance is 120 ohms. If the primary impedance of the LVDT being used is less than 120 ohms at the selected oscillator frequency, the 1 V oscillator output must be used. Similarly, the minimum load impedance for the 1V oscillator output is 40 ohms. If the primary impedance of the LVDT being used is less than 40 ohms at the selected oscillator frequency, try using a higher frequency if possible.

If the full scale output of the LVDT is greater than 2.5 V. rms. reduce the primary excitation to 1 V. If the full scale output is less than 0.05 V rms., increase the primary excitation to 3 V.

## Gain Selection

The LVDT full-scale output is given by the following equation:

**LVDT F/S output voltage = Sensitivity X Primary Voltage X Full Scale Displacement** where the LVDT FS output is in V. rms.

Sensitivity is in either **mV/V/.001"** or **mV/V/mm**. The sensitivity can be found either in the manufacturer catalog or on the LVDT's data sheet.

Full Scale Displacement is the plus / minus linear range of the LVDT, from the center zero null position.

The full stroke, or operating range of the LVDT, is two times the full scale. It is measured in thousandth of an inch or in mm depending on the units of the sensitivity. The units of the sensitivity and full-scale displacement must agree. They must both be in inches or in mm.

The primary voltage is either 3 V rms or 1 V rms as set by switch SW2-4.

Once you know the LVDT full scale output, the gain can be selected from the chart below:

Gain Number	For LVDT Full Scale Output In V rms.		Gains		Switch Positions		
	From	To	Gain 1	Gain 2	Switch 1-6	Switch 1-7	Switch 1-8
1	1.20	2.50	X 0.4	Low	On	Off	Off
2	0.78	1.20	X 0.4	High	Off	Off	Off
3	0.40	0.78	X 1.2	Low	On	Off	On
4	0.26	0.40	X 1.2	High	Off	Off	On
5	0.13	0.26	X 3.63	Low	On	On	Off
6	0.10	0.13	X 3.63	High	Off	On	Off
7	0.05	0.10	X 4.4	High	Off	On	Off

## Calibration

- The first step is to zero the electronics. To do this we need to disconnect the input signal. This is best achieved by disconnecting the LVDT wiring as close to the LVDT as possible. This will allow you to correct for any zero shift caused by the cabling.

Using the ZERO control on the front panel, adjust until the output reads 12 mA.

0.0 V dc for  $\pm 5$  V dc Output

2.5 V dc for 0 to +5 V dc Output

5.0 V dc for 0 to +10 V dc Output

**12.0 mA for 4 to 20 mA output**

- Next, we zero the LVDT by finding its electrical null point. Reconnect the LVDT and move the core connecting rod or plunger of the LVDT until the output reads 12 mA. The core of the LVDT should now be approximately in the center of the LVDT. This is the null position of the LVDT from which the plus and minus displacements are measured.

NOTE: If this adjustment is mechanically difficult or impractical, approximate the correct position as closely as possible and then turn the ZERO control to obtain a zero reading.

- Next, adjust the phase of the reference signal for the demodulator. Using the connecting rod or plunger, move the core toward the lead or connector end of the LVDT approximately 70 to 80% of the plus full-scale displacement.

NOTE: Positive full scale displacement for an LVDT is the maximum rated displacement of the core into the LVDT from the null position toward the lead exit or connector end of the LVDT. This should result in an increasing output from the LDM-100, toward 20 mA. To reverse the output polarity, interchange the secondary connections on terminals 3 and 4 of P1.

- This part of the calibration does not have to be precise. Adjust the front panel PHASE control in the direction that increase the output current, (usually clockwise). Continue to adjust the PHASE control until the output peaks, that is the position where the output current decreases, regardless of the direction the PHASE control is turned. If the output does not peak and the PHASE control is at the end of its adjustment, leave it there and continue with the calibration.

If at any point during the phase adjustment the output exceeds 20 mA, reduce the output signal back toward 12 mA by adjusting SPAN control. Then continue with the phase adjust operation.

- Return the core back to the original zero position (12 mA), It should still be the same location, If not, make a small adjustment with the ZERO control to obtain the 12 mA reading.
- Displace the core towards the leads precisely, half the intended full measurement span, using a micrometer, gage blocks, or other displacement standard. This position should be the maximum full-scale position over which you intend to operate.
- Using the front panel SPAN control, adjust the conditioner for full scale output of 20 mA.

If the required full-scale reading cannot be obtained by adjusting the SPAN control, the gain of the signal conditioner may be increased or decreased by changing the internal dip switches to the next higher or lower gain range.

Re-check the 12 mA output at the LVDT null point. You may displace the core full-scale displacement away from the leads (minus full scale) to check for symmetry, (4 mA).



A Division of Measurement Specialties Inc.

# Distribuidor

Brasil e América do Sul

## CONTATO

### Endereço

Rua Sete de Setembro, 2671 - Centro  
13560-181 - São Carlos - SP - Brasil

### Telefone

+55 (16) 3371-0112

### Fax

+55 (16) 3372-7800

### Internet

[www.metrolog.net](http://www.metrolog.net)  
[metrolog@metrolog.net](mailto:metrolog@metrolog.net)

