

# ATA-2001 LVDT Amplifier

True Analog Conditioner with Digital Calibration

## DESCRIPTION

The new Schaevitz® analog transducer amplifier is a general purpose, AC line-powered LVDT/RVDT conditioner featuring state-of-the-art design principles. The new SMT (Surface Mount Technology) design uses an embedded microprocessor to generate a PWM-shaped sine wave and control all calibration functions. The processor is also employed in the demodulation, filtration and synchronization of the LVDT signal. All settings are stored in non-volatile memory for restoration on power up. Zero, Span and Phase adjustments are accomplished via the use of splashproof front panel pushbuttons and digital voltage dividers, eliminating the need for drift-inducing screw adjust potentiometers. All amplifier controls are accessible from the outside of the rugged aluminum enclosure.

The new ATA 2001 is CE certified, and is intended for the most rigorous, industrial applications. The ATA 2001 has been tested to the highest industrial standards for EMI, RFI and ESD.

The ATA 2001 is designed for universal compatibility with all 4, 5, and 6 lead LVDTs. A wide range of oscillator frequencies combined with two excitation voltages, 3.5 and 0.5 Vrms, provide maximum versatility. The high power carrier amplifier has more than twice the drive capability of previous designs. Able to power low



impedance LVDTs at higher amplitudes, the ATA 2001 provides measurement resolutions beyond any product currently available.

The ATA 2001 is contained within a rugged, extruded aluminum housing. The one-piece design provides optimal amplifier performance under the most rigorous EMI and RFI conditions. An integral panel mounting system provides for convenient 1/8 DIN standard, panel installation. Pre-punched 19" rack adapters are available from Schaevitz® to accommodate up to eight amplifiers per adapter installation.

## FEATURES

- ◆ 2.5, 5.0 and 10.0 kHz Switch Selectable Excitation
- ◆ Digital Filtering
- ◆ CE Certified
- ◆ Switch Selectable 115 or 220 VAC Operation
- ◆ Voltage and Current Outputs
- ◆ Microprocessor Controlled Calibration and Synchronization
- ◆ 1/8 DIN Standard Panel Mounting
- ◆ Splashproof Front Panel with Status LEDs

## APPLICATIONS

- ◆ Control Valve Position Feedback
- ◆ Head Box Slice Lip Position Control
- ◆ Precision Metrology Labs
- ◆ Roller Gap Position Feedback

## OPTIONS

- ◆ Rack Adaptor Holds Up to 8 ATAs

## Auto Fall-Back Synchronization

An auto fall-back synchronization feature allows reliable master/slave operation, for prevention of amplifier cross talk, without the worry of sync signal loss. If the internal processor in a slave amplifier detects an unstable or missing sync signal, the internal clock will take over, continuing at the preselected nominal frequency. Upon restoration of a normal sync pulse, the oscillator will return to the slave mode.

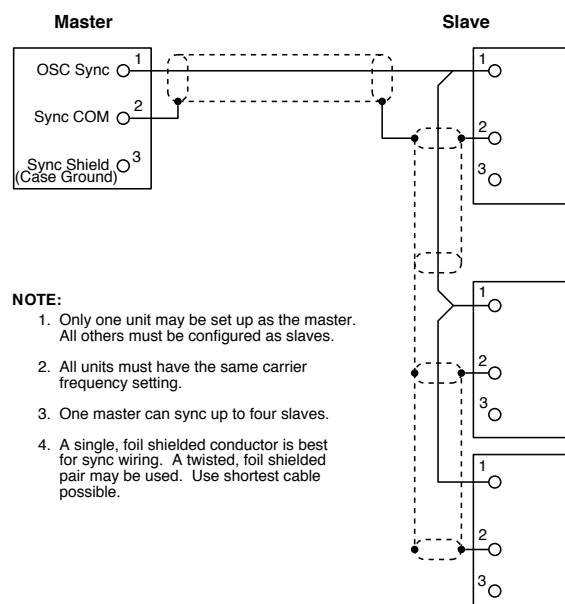

# ATA-2001 LVDT Amplifier

## specifications

### Electrical:

**Power Requirements** 115 VAC  $\pm 10\%$ , 50-400 Hz; 220 VAC  $\pm 10\%$ , 50-400 Hz

(switch selectable)

**Line Voltage Regulation**  $\pm 10\%$ , no change in output

### Transducer Excitation

**Voltage** 3.5 V rms nominal (switch selectable for 0.5 V rms)

**Frequency** 2.5, 5.0 and 10.0 kHz (switch selectable)

**Current** 45 mA rms (max)

### Analog Output:

#### Voltage Output

**Bipolar**  $\pm 10$  VDC max (10 mA max)

**Unipolar** 0-10 VDC max (10 mA max)  
(with 100% zero suppression)

**Output Impedance**  $< 1\Omega$

**Noise and Ripple**  $< 3$  mV rms at 2.5 kHz excitation

**Current Output** 4-20 mA

#### Maximum Loop

**Resistance** 700 (with internal loop supply);  
1000 (with 24 VDC external loop supply)

**Noise and Ripple** 10  $\mu$ A rms (max)

**Frequency Response (nom):** -3 db at 250 Hz for 2.5 kHz

excitation 500 Hz for 5.0 kHz

excitation 1000 Hz for 10 kHz

excitation

### Amplifier Characteristics:

#### Sensitivity Range

**High Gain** 0.040 to 0.9 VAC rms in = 10 VDC output

**Low Gain** 0.500 to 10.0 VAC rms in = 10 VDC output  
Note: -5 VDC output = 4.0 mA current output; +5 VDC output = 20 mA current output; 0 VDC output = 12 mA current output

**Input Impedance** 100k $\Omega$

**Zero Suppression**  $\pm 110\%$  full scale output

#### Phase Shift

**Compensation**  $\pm 120^\circ$  maximum

#### Non-linearity and

**Hysteresis**  $< \pm 0.05\%$  of full scale output

**Stability** Better than  $\pm 0.05\%$  of full scale output (after 20 minutes)

**Tempco**  $< \pm 0.02\%$  of full scale output/ $^\circ$ F  
(0.04%/ $^\circ$ C)

**Operating Temp. Range** -40 $^\circ$  to 185 $^\circ$ F (-40 $^\circ$  to 85 $^\circ$ C)

**Weight** 2.1 lbs (950 g)

## dimensions

in (mm)

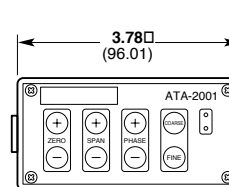
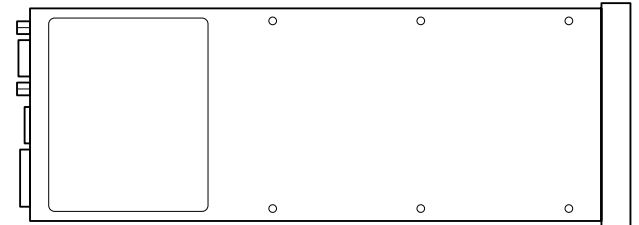
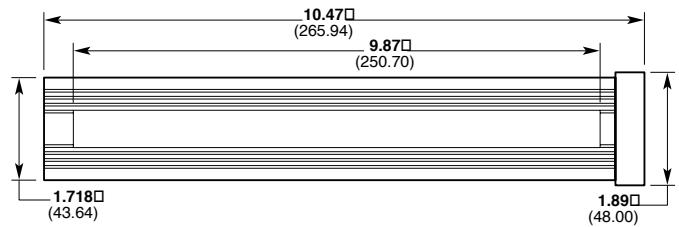

FRONT

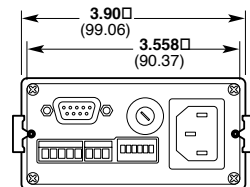

REAR

## ordering information

Order by model number

**Model Number** **ATA-2001**  
Optional rack adaptor (holds eight ATAs).

# ATA-2001 LVDT Amplifier

## input schematics

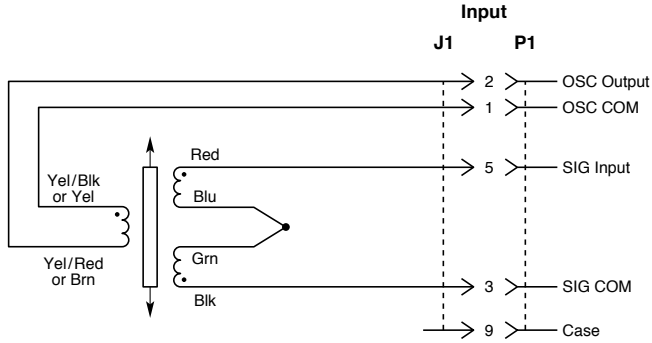

LVDT with Leads or Cable

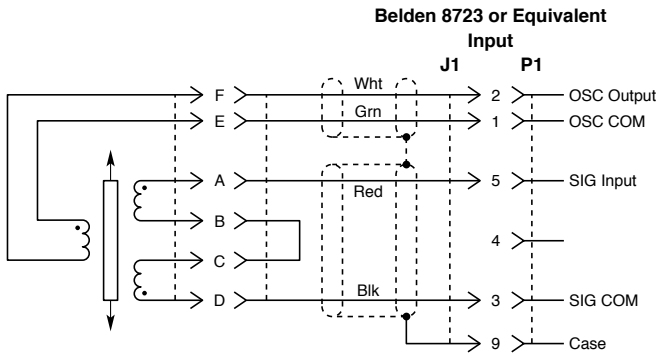

LVDT with Connector

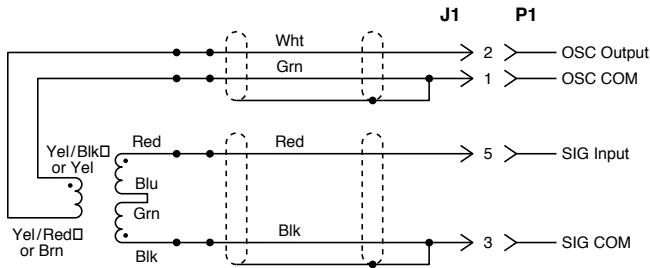

LVDT with Leads and Spliced Cable

### Input Connections - LVDT with Connector

Connect to Input J1	Pin 1	Pin 2	Pin 3	Pin 5	Pin 9
LBB315PA-200□ PCA-499	Blue	Red	White	Green	Shield
All other LBBs and□ color coded LVDTs	Yel / Blk□ or Yel	Yel / Red□ or Brn	Black	Red	Shield
Letter coded	E	F	D	A	

**NOTE:** Center tap must be tied at LVDT in all cases.

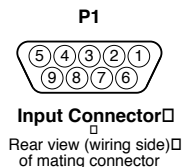

### Input Connections—LVDT with Connector

## output schematics

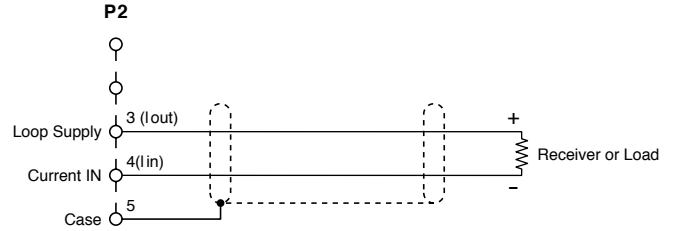

Voltage Output

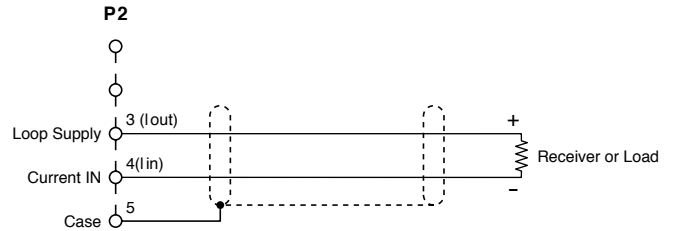

4-20 mA Current Output Using the Internal Loop Supply

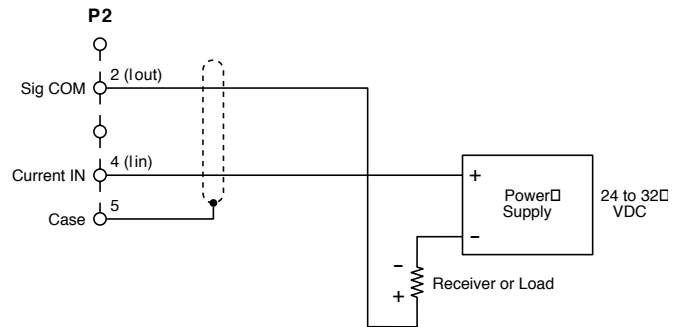

4-20 mA Current Output Using the External Loop Supply

# ATA-2001 LVDT Amplifier

## rack adaptor option

Accommodates up to eight ATA amplifiers (page 104), eight PML 1000s, or four MP Series Readout/Controllers.

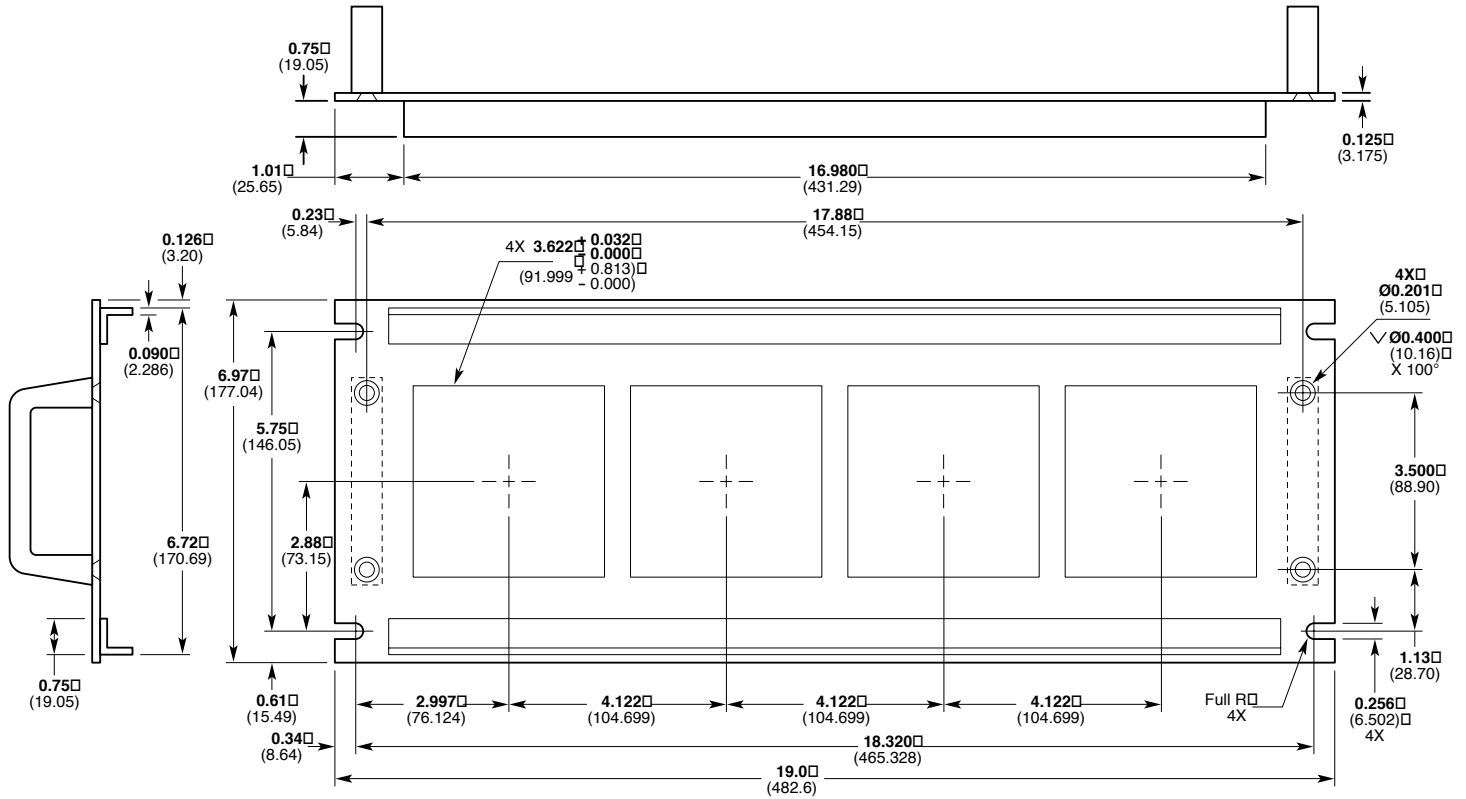

## ordering information

Order by model number

**Model Number**      **RACK ADAPTOR**

# Distribuidor

Brasil e América do Sul

## CONTATO

### Endereço

Rua Sete de Setembro, 2671 - Centro  
13560-181 - São Carlos - SP - Brasil

### Telefone

+55 (16) 3371-0112

### Fax

+55 (16) 3372-7800

### Internet

[www.metrolog.net](http://www.metrolog.net)  
[metrolog@metrolog.net](mailto:metrolog@metrolog.net)

