

AP Series Customizable OEM Gage Heads

±1.0mm to 2.5mm Range; Spring-Extend Design

Linear Ball Bearing Design

Spring-Extend

DESCRIPTION

The Analog Probe (AP) series - LVDT gage head is designed to meet the most demanding requirements of OEM tooling designers and builders. Designed by Measurement Specialties Inc (MEAS), the first LVDT manufacturer (under our Schaevitz® Brand) and world leader in industrial linear displacement sensors, the AP series gage head was designed utilizing over 60 years of LVDT design expertise.

Meas-Spec has revolutionized gage head manufacturing technology with the implementation of fully automated, ultra high precision CNC machining centers. The new design has been optimized to take maximum advantage of process automation thereby eliminating costly and time consuming hand fitting of high tolerance components, resulting in a highly consistent, low cost manufacturing process.

Assembled in the USA, at our ISO and AS-9100 certified Hampton, Virginia manufacturing facility, this OEM gage head has a modular design allowing for easy customization to solve your unique OEM application requirements. The flexibility of US manufacturing reduces lead times and stock-out situations.

FEATURES

- ◆ Calibrated Over ±1.0mm to ±2.5mm
- ◆ Ultra-Precision Performance
- ◆ AC-Operated
- ◆ User-Adjustable Pretravel and Overtravel Settings
- ◆ 8 mm or 9.5 mm Body Diameter
- ◆ Plain or Threaded Housing
- ◆ Calibration Certificate Supplied with Every Gage Head
- ◆ Compatible with All Schaevitz® Signal Conditioners
- ◆ Connector Options
- ◆ Special Contact Tips
- ◆ Assembled in USA for Maximum Flexibility



APPLICATIONS

- ◆ Automotive machine parts SPC inspection - engine, brake rotor and power train component dimensions
- ◆ Aircraft engine component inspection - turbine blade thickness and flow turbine shaft torquing and run-out
- ◆ Assembly line, in-process measurements
- ◆ Prosthetic joint and limb testing fitting
- ◆ Robotics
- ◆ SPC monitoring of machine part dimensions
- ◆ Bore/Depth gage hand tools
- ◆ Position feedback for X/Y tables
- ◆ PCB drilling machines
- ◆ Z-axis control for wire die bonding machines

AP Series Customizable OEM Gage Heads

±1.0mm to 2.5mm Range; Spring-Extend Design

common specifications

Input Frequency	2.5 to 10 kHz
Linearity	< ±0.20% of full range output
Repeatability	0.000004" (0.10µm)
Operating	
Temp. Range	-45°F to 160°F(-40°C to 70°C)
Temperature Coefficient of Sensitivity	
	±0.005% of full range output/°F (±0.01% of full range output/°C)
Housing Material	Hardened stainless steel
Cable	6.5 feet (2 meters), 32 AWG stranded, PTFE insulated, shielded polyurethane jacket, 6 conductor
Cable Exit	Axial standard; adaptor available to allow for radial exit



electrical specifications

Excitation	3.5 V rms at 5.0 kHz (nom)
Sensitivity	5.0 – 5.5 mV/V/.001"
Null Voltage	5.0 mV (max)
Phase Shift	3.0° ±3°
Primary Impedance	960 ohms
Secondary Impedance	2150 ohms

wiring

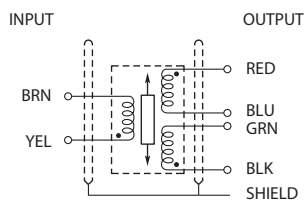

Note:
BLU and GRN tied for differential output with YEL and BLK common. The output is in phase, with core displaced toward cable end. (Retract)

ordering information

AP - X.Xmm - YYYY

(X.X is the range in MM, for example 1.0 or 2.5)
(YYYY is the MEAS special number assigned to your custom design)

mechanical specifications

Linear Range	±1.0mm - ±2.5mm
Pretravel	0.000" to 0.015"
Overtravel	0.005" (min)
Probe Force	70g typical (customized) 50 to 100g at null
Body Diameter	8mm or 9.5mm
Body Type	Plain or threaded
Customized Cable Length	6.5' (2.0m) standard
Tip Thread	4-48 AGD

dimensions

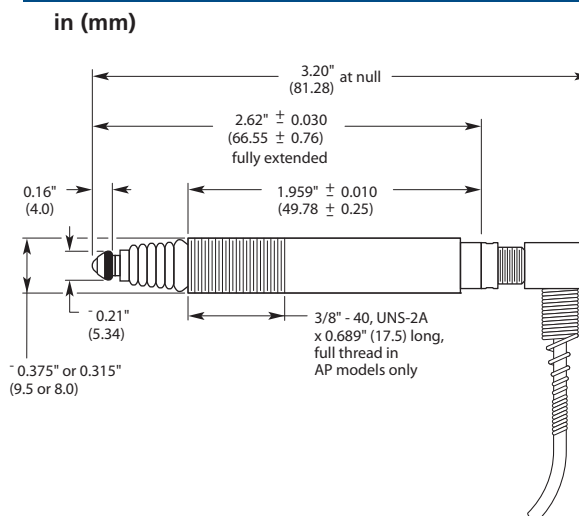

Distribuidor

Brasil e América do Sul

CONTATO

Endereço

Rua Sete de Setembro, 2671 - Centro
13560-181 - São Carlos - SP - Brasil

Telefone

+55 (16) 3371-0112

Fax

+55 (16) 3372-7800

Internet

www.metrolog.net
metrolog@metrolog.net

