

XS-ZTR Series

Nuclear Radiation Resistant LVDT

DESCRIPTION

The **XS-ZTR Series** LVDT is designed for measuring displacement at very high and cryogenic temperatures. The XS-ZTR operates continuously at 550°C and will survive 650°C for several hours. The XS-ZTR is also designed to perform within specification after exposure to a total integrated flux of 10^{11} rads gamma or 3×10^{20} NVT.

The XS-ZTR is made exclusively from inorganic materials, principally metals and ceramics. Windings are of ceramic insulated precious metal alloys; joints are welded or brazed with high temperature alloys. Leads are sheathed in stainless steel. Conductors are typically nickel with magnesium oxide insulation. Materials are selected to have compatible expansion coefficients in order to minimize thermal stresses. Most inorganic insulations are hygroscopic so the entire coil assembly is weld sealed into a stainless steel shell. This process prevents moisture accumulation and insulation leakage. It also seals out hostile surrounding media while permitting the core to move freely. The cable can be terminated by a sealed header or connector when required.

FEATURES

- ◆ Withstands Total Integrated Neutron Flux Levels to 3×10^{20} NVT
- ◆ Withstands total integrated radiation of 10^{11} rads or 10^9 gray
- ◆ Suitable For Continuous Operation From -320°F (-195°C) Up to 1022°F (550°C)
- ◆ Survives Non-Operating Temperatures Up to 1200°F (650°C)
- ◆ Special Temperature Calibrations Available
- ◆ Calibration Certificates Supplied with All Models

APPLICATIONS

- ◆ Material Testing in Pressurized Autoclaves
- ◆ Nuclear Reactor Containment Vessel Bolt Tension
- ◆ Cryogenic Medicine
- ◆ Space Research
- ◆ Jet Engine Gimbal Position Feedback
- ◆ Roll Gap On Steel Hot Strip and Slabbing Mills

OPTIONS

- ◆ Metric Thread Core



For moderate temperature and radiation applications, consider the HR or HCA LVDTs (with 080 option), or the MHR series (with special order vented case).

Radiation Resistance

Certain applications require resistance to a combination of gamma radiation, neutron radiation and high temperature. Before considering detailed specifications and suitability for a particular application a review of some working definitions and equivalents is in order:

nvt = integrated flux or fluence
= neutron density x velocity x time
= $n/m^3 \times m/s \times s$
= n/m^2

rad = radiation absorbed dose
= radiation that will deposit 100 ergs per gram

$n/cm^2 = 4.17 \times 10^{-9}$ rads

$n/cm^2 = 4.17 \times 10^{-7}$ ergs/gm

1 Gray (gy) = 100 rad absorbed dose

1 rad/hr = approximately 7×10^8 neutrons/ m^2s^2

All radiation produces some damage, therefore, the issue becomes how much radiation and what kind of radiation can an object sustain while maintaining its operation specification. At best, this can only be an estimate.

When radiant energy falls on an object, equal amounts of energy from different sources may result in greatly differing amounts of damage depending on the form of radiation, i.e. gamma rays, neutrons, etc. These different sources may also result in qualitatively different kinds of damage. One method to quantify these differences is to determine the rate of radiation that a unit can withstand without instantaneous and unacceptable damage. Another method is to determine the total integrated flux that can be absorbed before "wear-out" damage from radiation occurs. The distinction between rate of flux and total integrated flux must be kept clearly in mind.

There is no direct relationship between neutron fluence and gamma radiation. If we assume equal energy dissipation from differing sources, the energy absorbed by the unit will vary with its absorption cross section. If we try to equalize damage, there is even more uncertainty because of the qualitative differences of the damage caused by various forms of radiation.

XS-ZTR Series

performance and electrical specifications @ 2.5 kHz¹

XS-ZTR Series Model	Nominal Linear Range		Linearity (±% full range)	Sensitivity mV out/V in Per		Impedance Ohms		Phase Shift Degrees
	inches	mm		0.001 in	mm	Pri	Sec	
100 XS-ZTR	±0.100	±2.54	0.5	1.3	51	95	250	-8
250 XS-ZTR	±0.250	±6.35	0.5	0.3	12	100	80	+20

¹All calibration is performed at room ambient temperature.

ordering information

Specify the XS-ZTR Model followed by the option number (if desired).

Ordering Example:

Model Number 100 XS-ZTR-006 is an XS-ZTR Series LVDT with a ±0.100 range (100 XS-ZTR), with a Metric thread core (006).

options

Number	Description
006	Metric Thread Core

specifications

Input Voltage	3 V rms (nominal)
Frequency Range	400 Hz to 5,000 Hz
Operating Temperature Range	-320°F to 1022°F (195°C to 550°C)
Survival Temperature Range	-450°F to +1200°F (-270°C to 650°C)
Null Voltage	<0.5% full scale output
Shock Survival	10 g for 11 msec
Vibration Tolerance	10 g up to 2 kHz
Coil Form Material	Ceramic
Housing Material	AISI 304 series stainless steel
Lead Wires	28 AWG solid nickel, MgO insulated, 72 inches (180 cm) long (nominal): 3/16 inch (4.75 mm) diameter stainless steel sheath, 1/2 inch (12.5 mm) minimum bend radius

XS-ZTR Model

100 XS-ZTR
250 XS-ZTR

dimensions

in (mm)

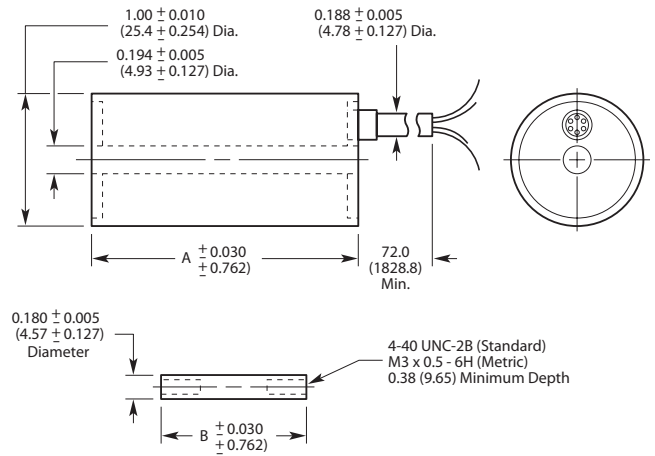

wiring

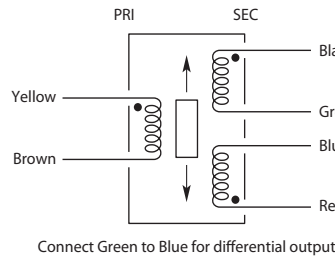

Standard termination is a multiple conductor 6-foot (1.8 m) long, 3/16 inch (4.75 mm) diameter swagged stainless steel cable. Other lengths and diameters are available on special order.

A frequently specified alternative termination is a pair of 2-conductor 1/16 inch (1.6 mm) diameter stainless steel sheathed cables. These are particularly suitable for applications where the cables are routed through an arduous path within the reactor.

mechanical specifications

XS-ZTR Series Model	Weight				Dimensions			
	Body		Core		A (Body)		B (Core)	
Number	oz	gm	oz	gm	in	mm	in	mm
100 XS-ZTR	2.29	65	0.09	2.5	2.51	63.8	1.35	34.3
250 XS-ZTR	4.06	115	0.28	8.0	3.83	97.2	1.35	34.3

* With 6-foot cable

Distribuidor

Brasil e América do Sul

CONTATO

Endereço

Rua Sete de Setembro, 2671 - Centro
13560-181 - São Carlos - SP - Brasil

Telefone

+55 (16) 3371-0112

Fax

+55 (16) 3372-7800

Internet

www.metrolog.net
metrolog@metrolog.net

