



MODEL 23 Medium Pressure

PC Board Mountable Pressure Sensor

0-100 mV Output

Gage and Absolute Pressure

Temperature Compensated

DESCRIPTION

The Model 23 is a temperature compensated, piezoresistive silicon pressure sensor packaged in TO-8 configurations. It provides excellent performance and long-term stability.

Gage and absolute pressure ranges from 0-2 PSI to 0-250 PSI are available. Integral temperature compensation is provided over a range of 0-50°C using laser-trimmed resistors. An additional laser-trimmed resistor is included to normalize pressure sensitivity variations by programming the gain of an external

differential amplifier. This provides sensitivity interchangeability of $\pm 1\%$.

Please refer to the low pressure section for information on products with operating pressures less than 0-2 PSI. For sensors in a dual-in-line package please refer to the Models 1210 and 1220.



FEATURES

- ◆ TO-8 Package
- ◆ +/-1% Non-linearity
- ◆ +/-5% Temperature Performance
- ◆ 1.0% Interchangeable Performance (provided by gain set resistor)
- ◆ Solid State Reliability
- ◆ Low Power

APPLICATIONS

- ◆ Medical Instruments
- ◆ HVAC
- ◆ Process Control
- ◆ Vacuum Measurement
- ◆ Air Flow Management

dimensions

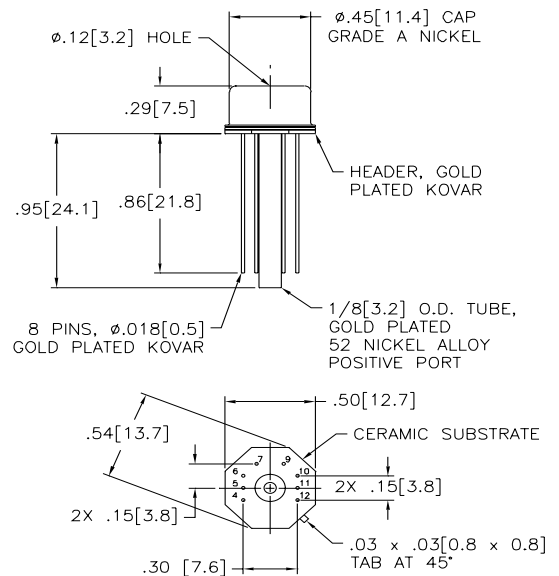

DIMENSIONS ARE IN INCHES [mm]

standard ranges

Range	psig
0 to 2	•
0 to 5	•
0 to 10	•
0 to 15	•
0 to 30	•
0 to 50	•
0 to 100	•
0 to 250	•



MODEL 23 Medium Pressure

performance specifications

Supply Current: 1.5 mA

Ambient Temperature: 25°C (Unless otherwise specified)

PARAMETERS	MIN	TYP	MAX	UNITS	NOTES
Full Scale Output Span	75	100	150	mV	
Full Scale Output Span (2 psi version)	30		60	mV	
Zero Pressure Output			2	±mV	
Pressure Non-linearity		0.05	0.10	±%Span	1
Pressure Hysteresis		0.01	0.05	±%Span	
Input & Output Resistance	2500	4400	6000	Ω	
Temperature Error - Span		0.3	0.5	±%Span	2
Temperature Error - Zero		0.1	0.5	±%Span	1,2
Thermal Hysteresis - Span		0.1		±%Span	2
Thermal Hysteresis - Zero		0.1		±%Span	2
Supply Current		1.5	2.0	mA	3
Response Time		1.0		msec	4
Output Noise	2			μV p-p	5
Output Load Resistance	2			MΩ	6
Insulation Resistance (50 VDC)	50			MΩ	7
Pressure Overload			3X	rated	8
Operating Temperature	-40°C to +125°C				
Storage Temperature	-50°C to +150°C				
Acceleration	50g Max				
Shock	1000g Peak for 0.5mS				
Vibration	20g Peak at 10 to 2000 Hz				
Media	Non-corrosive Gases				
Weight	3 grams				

1. Best Fit Straight Line. For 2 psi output span is 30-60 mV and TC zero temperature error is ±1.25%.
2. Temperature range 0-50°C in reference to 25°C.
3. Guarantees input/output ratiometricity for span.
4. For a zero-to-full scale pressure step change.
5. 10 Hz to 1 kHz.
6. Prevents increase of TC Span due to output loading.

7. Between case and sensing element.
8. 3X not to exceed 500 psi on ranges: 0-10 psi to 0-250 psi; 20 psi for 2 psi and 5 psi versions.
9. For Top Entry versions, wetted materials are silicon, aluminum, gold, RTV, glass, and nickel. For Bottom Entry versions, wetted materials are silicon, RTV, gold, and glass.
10. For backside application, 3X not to exceed 100 psi on all ranges.

ordering information

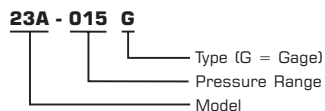

connections

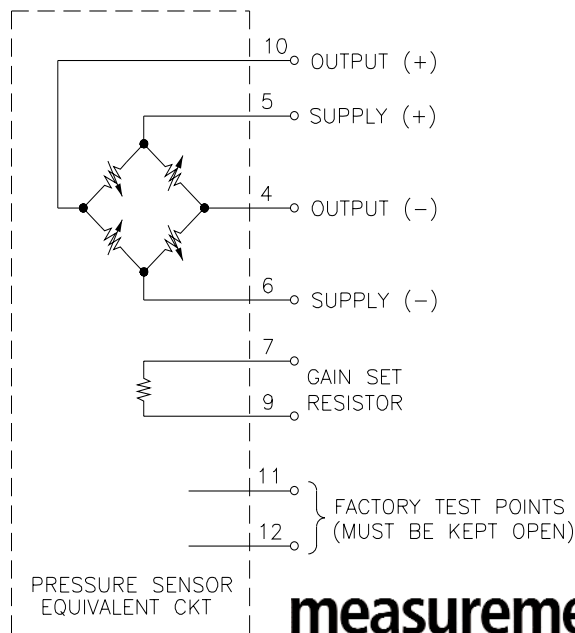

application schematic

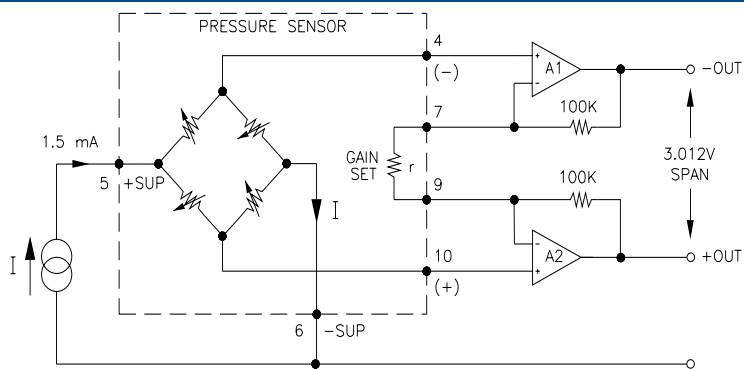

FIGURE 1: BOTTOM ENTRY FOR GAGE

Distribuidor

Brasil e América do Sul

CONTATO

Endereço

Rua Sete de Setembro, 2671 - Centro
13560-181 - São Carlos - SP - Brasil

Telefone

+55 (16) 3371-0112

Fax

+55 (16) 3372-7800

Internet

www.metrolog.net
metrolog@metrolog.net

