

MODEL 1240 **ultrastable**



PC Board Mountable Pressure Sensor
0-150 mV Output
Absolute, Differential and Gage
Temperature Compensated

DESCRIPTION

The **Model 1240** is a high performance temperature compensated, piezoresistive silicon pressure sensor packaged in a dual-in-line configuration and intended for cost sensitive applications where excellent performance and long-term stability are required.

Integral temperature compensation is provided over a range of -20°C to +85°C using laser-trimmed resistors. An additional laser-trimmed resistor is included to normalize pressure sensitivity variations, for interchangeability of ±1%.

Gage and Differential pressure ranges from 0-15 PSI to 0-100 PSI are available. Absolute pressure ranges of 0-15 PSIA and 0-30 PSIA are available. Multiple lead and tube configurations are also

available for customizing the package for specific applications.

Please refer to the low pressure section for information on products with operating pressures less than 0-2 PSI. For a compensated sensor using a gain set resistor as opposed to a current set resistor, please refer to the Model 1230.

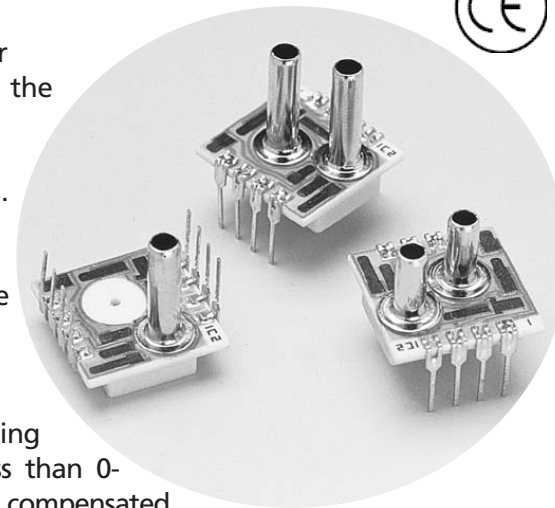

FEATURES

- ◆ Dual-in-line Package
- ◆ -20°C to +85°C Compensated Temperature Range
- ◆ ±0.1% Non-linearity
- ◆ ±0.5% Temperature Performance
- ◆ 1.0% Interchangeable Span (provided by gain set resistor)

- ◆ Solid State Reliability
- ◆ Low Power

APPLICATIONS

- ◆ Medical Instrumentation
- ◆ Calibration
- ◆ Process Control
- ◆ Factory Automation
- ◆ Air Flow Management
- ◆ Leak Detection

Dimensions

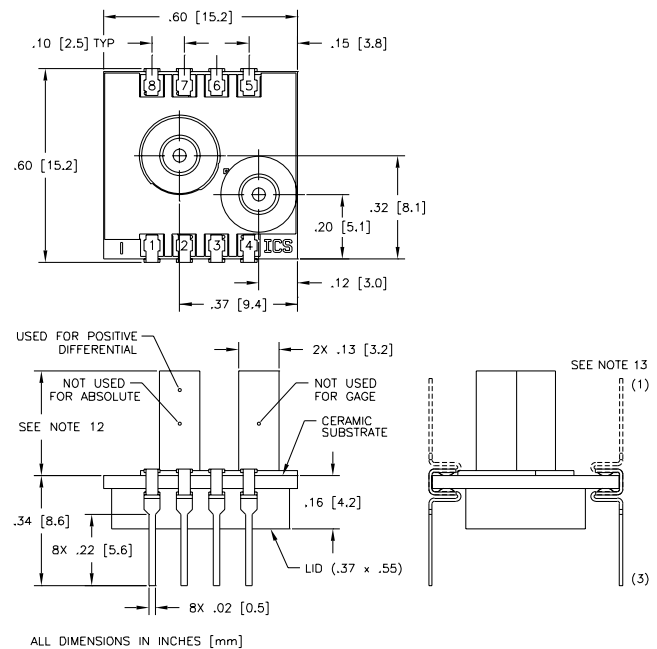

Standard Ranges

Range	psia	psid	psig
0 to 15	•	•	•
0 to 30	•	•	•
0 to 50	•	•	•
0 to 100	•	•	•



MODEL 1240 Ultrastable

performance specifications

Supply Voltage: See application schematic

Ambient Temperature: 25°C (Unless otherwise specified)

PARAMETERS	MIN	TYP	MAX	UNITS	NOTES
Full Scale Output Span	49.5	50	50.5	mV	1,3
Zero Pressure Output			2	±mV	3
Pressure Non-linearity		0.05	0.1	±% Span	2
Pressure Hysteresis		0.01	0.1	±% Span	
Input Resistance	2500	3500	4500	□	
Temperature Error - Span		0.3	0.5	±% Span	3,4
Temperature Error - Zero		0.1	0.5	±% Span	3,4
Temperature Coefficient - Resistant		0.145		%/°C	4
Thermal Hysteresis - Zero		0.05		±% Span	4
Short Term Stability of Offset		0.05		±% Span	13
Short Term Stability of Span		0.05		±% Span	13
Long Term Stability of Offset		0.1		±% Span	14
Long Term Stability of Span		0.1		±% Span	14
Response Time (10% to 90%)		1.0		msec	5
Output Noise		1.0		µV p-p	6
Output Load Resistance	5			M□	7
Insulation Resistance (50 VDC)	50			M□	
Pressure Overload			3X	Rated	9
Operating Temperature	-40°C to +125°C				
Storage Temperature	-50°C to +150°C				
Media	Non-Corrosive Gases Compatible with Wetted Materials				9
Weight	3 Grams				

Notes

1. Output span of unamplified sensor using current set resistor.
2. Best Fit Straight Line.
3. Compensation resistors are an integral part of the sensor package; no additional external resistors are required. Pins 7 and 8 must be kept open.
4. Temperature range: -20 to +85°C in reference to 25°C.
5. For a zero-to-full scale pressure step change.
6. 10 Hz to 1 kHz.
7. Prevents increase of TC-Span due to output loading.
8. 3X or 200 psi maximum, whichever is less.
9. Wetted materials are glass, ceramic, silicon, RTV, nickel, gold, and aluminum.
10. Soldering of lead pins: 250°C for 5 seconds maximum.
11. Tube length: L=470 ± 5 mil, S=300 ± 3 mil, N=no tube.
12. Lead pins can either be in the same or the opposite direction as the pressure tube. See Connections/Dimensions drawing for lead configurations.
13. Normalized offset bridge voltage: 7 days.
14. 1 year.

Ordering Information

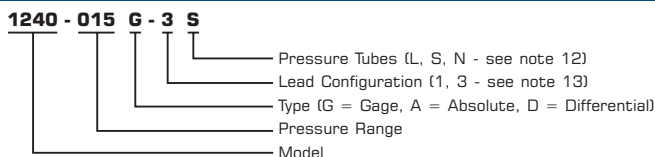

Application Schematic

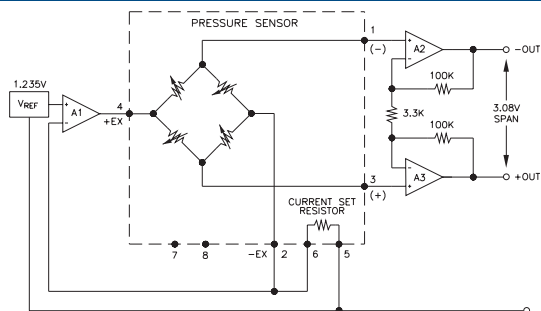
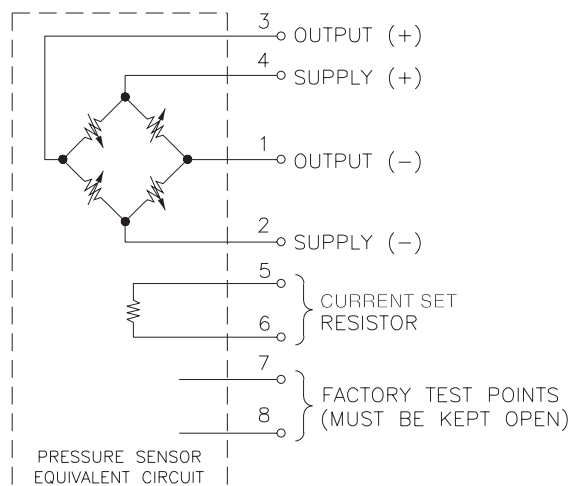

FIGURE 1: CURRENT SET CIRCUIT

Connections



Distribuidor

Brasil e América do Sul

CONTATO

Endereço

Rua Sete de Setembro, 2671 - Centro
13560-181 - São Carlos - SP - Brasil

Telefone

+55 (16) 3371-0112

Fax

+55 (16) 3372-7800

Internet

www.metrolog.net
metrolog@metrolog.net

