

MODEL 1230 **Ultrastable**



PC Board Mountable Pressure Sensor

0-100 mV Output

Absolute, Differential and Gage

Wide Temperature Range

DESCRIPTION

The **Model 1230** is a high performance temperature compensated, piezoresistive silicon pressure sensor packaged in a dual-in-line configuration. It is intended for cost sensitive applications where excellent performance and long-term stability are required.

Integral temperature compensation is provided over a range of -20°C to +85°C using laser-trimmed thick film resistors. An additional laser-trimmed resistor is included to normalize pressure sensitivity variations, for interchangeability of ±1%, by programming the gain of an external differential amplifier.

Differential and gage pressure ranges from 0-15 PSI to 0-100 PSI are available. Absolute pressure ranges of 0-15 PSIA to 0-30 PSIA are available.

Multiple lead and tube configurations are available for different applications. Please refer to the low pressure section for information on products with operating pressures less than 0-2 PSI. For a compensated sensor using a current set resistor as opposed to a gain set resistor, please refer to the Model 1240.

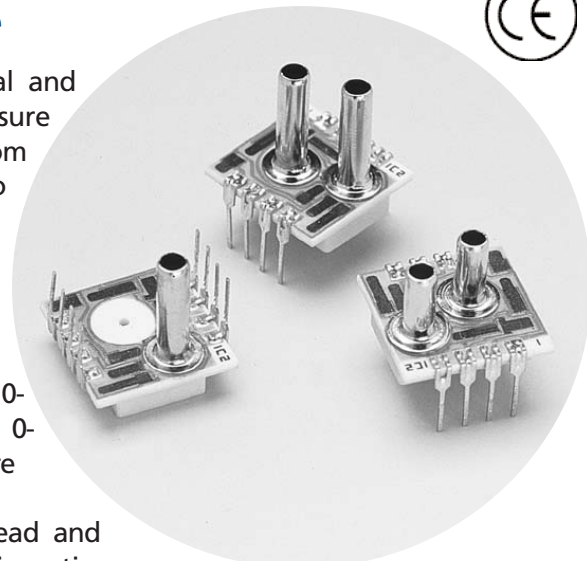

FEATURES

- ◆ Dual-in-line Package
- ◆ -20°C to +85°C Compensated Temperature Range
- ◆ ±0.1% Non-linearity
- ◆ ±0.5% Temperature Performance
- ◆ 1.0% Interchangeable Span (provided by gain set resistor)
- ◆ Solid State Reliability
- ◆ Low Power

APPLICATIONS

- ◆ Medical Instrumentation
- ◆ Calibration
- ◆ Process Control
- ◆ Factory Automation
- ◆ Air Flow Management
- ◆ Leak Detection

Dimensions

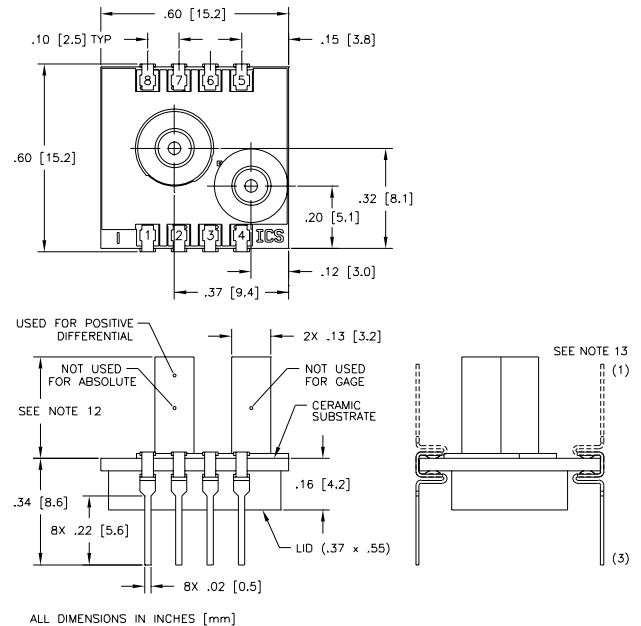

Standard Ranges

Range	psia	psid	psig
0 to 15	•	•	•
0 to 30	•	•	•
0 to 50	•	•	•
0 to 100	•	•	•



MODEL 1230 **ultrastable**

performance specifications

Supply Current: 1.5mA

Ambient Temperature: 25°C (Unless otherwise specified)

PARAMETERS	MIN	TYP	MAX	UNITS	NOTES
Full Scale Output Span	75	100	150	mV	1
Zero Pressure Output			2	±mV	3
Pressure Non-linearity		0.05	0.1	±% Span	2
Pressure Hysteresis		0.01	0.1	±% Span	
Input Resistance	2500	3500	4500	□	
Temperature Error - Span		0.3	0.5	±% Span	3,4
Temperature Error - Zero		0.1	0.5	±% Span	3,4
Temperature Coefficient - Resistant		0.145		%/°C	4
Thermal Hysteresis - Zero		0.05		±% Span	4
Short Term Stability of Offset		0.05		±% Span	13
Short Term Stability of Span		0.05		±% Span	13
Long Term Stability of Offset		0.1		±% Span	14
Long Term Stability of Span		0.1		±% Span	14
Supply Current	0.5	1.5	2.0	mA	
Response Time (10% to 90%)		1.0		msec	5
Output Noise		1.0		µV p-p	6
Output Load Resistance	2			M□	7
Insulation Resistance (50 VDC)	50			M□	
Pressure Overload			3X	Rated	8
Operating Temperature	-40°C to +125°C				
Storage Temperature	-50°C to +150°C				
Media	Non-Corrosive Gases Compatible with Wetted Materials				9
Weight	3 Grams				

Notes

- Output span of unamplified sensor.
- Best Fit Straight Line.
- For Model 1230, compensation resistors are an integral part of the sensor package; no additional external resistors are required. Pins 7 and 8 must be kept open.
- Temperature range: -20°C to +85°C in reference to 25°C.
- For a zero-to-full scale pressure step change.
- 10 Hz to 1kHz.
- Prevents increase of TC-Span due to output loading.
- 3X or 200 psi maximum, whichever is less. 20 psi for 2 psi and 5 psi versions.
- Wetted materials are glass, ceramic, silicon, RTV, nickel, gold, and aluminum.
- Soldering of lead pins: 250°C for 5 seconds, maximum.
- Tube length: L=470 ± 5 mil, S=300 ± 3 mil, N=no tube.
- Lead pins can either be in the same or the opposite direction as the pressure tube. See Connections/Dimensions drawing for lead configurations.
- Normalized offset bridge voltage: 7 days.
- 1 year.

Ordering Information

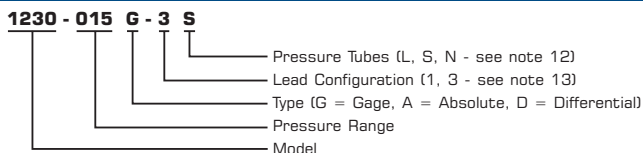

Connections

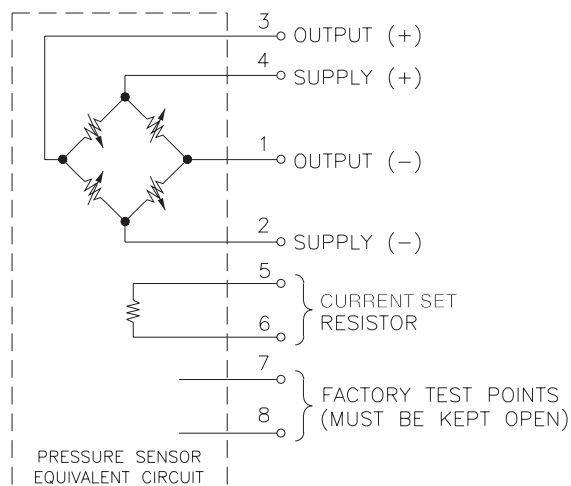

Application Schematic

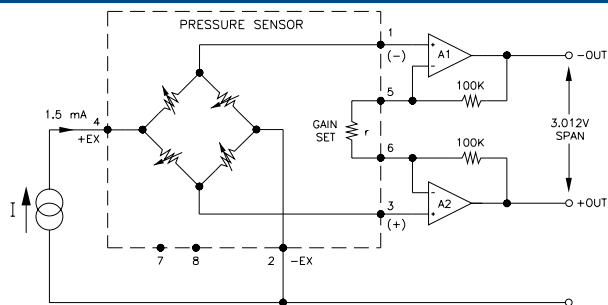

FIGURE 1: GAIN SET CIRCUIT

Distribuidor

Brasil e América do Sul

CONTATO

Endereço

Rua Sete de Setembro, 2671 - Centro
13560-181 - São Carlos - SP - Brasil

Telefone

+55 (16) 3371-0112

Fax

+55 (16) 3372-7800

Internet

www.metrolog.net
metrolog@metrolog.net

