

Model 1620 Pressure Sensor

Disposable Blood Pressure Sensor

AAMI Specification

Low Cost

Multiple Configurations

DESCRIPTION

The Model 1620 is a fully piezoresistive silicon pressure sensor for use in invasive blood pressure monitoring. The sensor is designed to be used with automated assembly equipment and can be dropped directly into a customer's disposable blood pressure housing. The sensor is designed to meet the requirements as described in the Association for the Advancement of Medical Instrumentation (AAMI) specification for Blood Pressure Transducers.

The pressure sensor consists of a pressure sensing element mounted on a ceramic substrate. Thick-film resistors on the ceramic substrate are laser-trimmed for compensation and calibration. A plastic cap is attached to the ceramic substrate to provide an easy method of attachment to the customer's assembly and protection for the sensing

element. A dielectric gel is placed over the sensor to provide electrical and fluid isolation.

The Model 1620 pressure sensors are batch manufactured in a 10x12 element array on a ceramic substrate (120 units per substrate). The products are shipped in anti-static shipping containers. They can also be shipped on a tape and reel. Performance characteristics and packaging can be easily tailored on a special order basis to meet the requirements of specific customers.

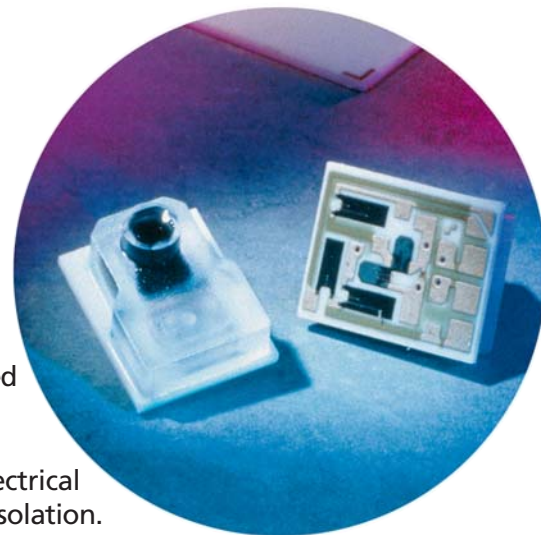

FEATURES

- ◆ Calibrated per AAMI Specifications
- ◆ Low Cost Disposable Design
- ◆ Solid State Piezoresistive Sensor
- ◆ Top Side Pressure Entry
- ◆ Compatible with Automated Assembly Equipment
- ◆ Integral Dielectric Gel Barrier
- ◆ Fully Tested and Temperature Compensated

APPLICATIONS

- ◆ Disposable Blood Pressure
- ◆ Kidney Dialysis Machines
- ◆ Medical Instrumentation
- ◆ Infusion Pumps

standard ranges

-50 to 300

mmHg

Model 1620 Pressure Sensor

performance specifications

Supply Voltage: 6.0 VDC

Ambient Temperature: 23°C (Unless otherwise specified)

PARAMETERS	MIN	TYP	MAX	UNITS	NOTES
Operating Pressure Range	-50		300	mmHg	
Overpressure	125			psi	
Zero Pressure Offset			±20	mmHg	
Sensitivity	4.95	5.0	5.05	µV/V/mmHg	
Calibration	97.5	100	102.5	mmHg	1
Linearity & Hysteresis (-30 to 100 mmHg)			1	mmHg	7
Linearity & Hysteresis (>100 to 200 mmHg)			1	% output	7
Linearity & Hysteresis (>200 to 300 mmHg)			1.5	% output	7
Input Impedance	1200		3200	Ω	
Output Impedance	285		315	Ω	
Output Symmetry	0.95		1.05	ratio	6
Supply Voltage	2	6	10	VDC or VAC RMS	
Risk Current (at 120 VAC rms 60 Hz)			2	µA	
Warm-up Time		5		seconds	
Frequency Response		1200		Hz	
Offset Drift			2	mmHg	2
Thermal Span Shift			±0.1	%/°C	3
Thermal Offset Shift			±0.3	mmHg/°C	3
Phase Shift (at 5 kHz)			5	degrees	
Light Sensitivity (3000 Foot Candle)		1		mmHg	
Defibrillator Withstand (400 Joules)	5			discharges	4
Sterilization (ETO)	3			cycles	5
Operating Temperature	+10°C to +40°C				
Storage Temperature	-25°C to +70°C				
Humidity (External)	10 - 90% (non-condensing)				
Operating Product Life	168 hours				
Shelf Life	3 years				
Dielectric Breakdown	10,000 VDC				
Media Interface	Dielectric Gel				
Volume Displacement	4.5 x 10 ⁻⁴ inches ³				
Weight	0.5 grams				

Notes:

- Output of sensor with no pressure applied and a 150K Ohms resistor shorted across +VIN to +OUT.
- Over an 8 hour time period after a 10 minute warm-up.
- Over operating temperature range (+10°C to +40°C).
- One discharge per minute performed by customer.
- Sterilization performed by customer. Compatible with ETO sterilization.
- Defined as common mode symmetry between signal output and either excitation terminal.
- Best fit straight line.
- Please contact factory for any customization.

Model 1620 Pressure Sensor

dimensions

All dimensions are in inches (millimeters).

CONNECTIONS AND DIMENSIONS

All dimensions are in inches (millimeters).

BODY STYLE N

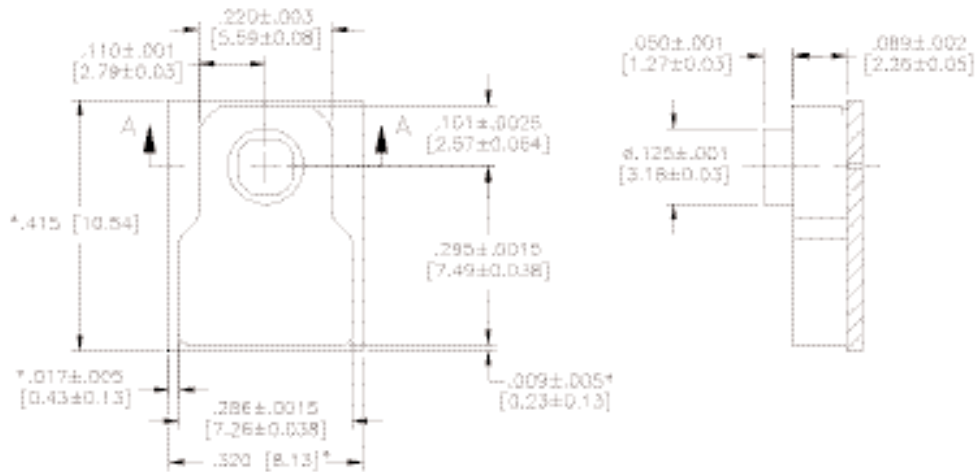

* Dimensions indicated do not include flares.

BODY STYLE W

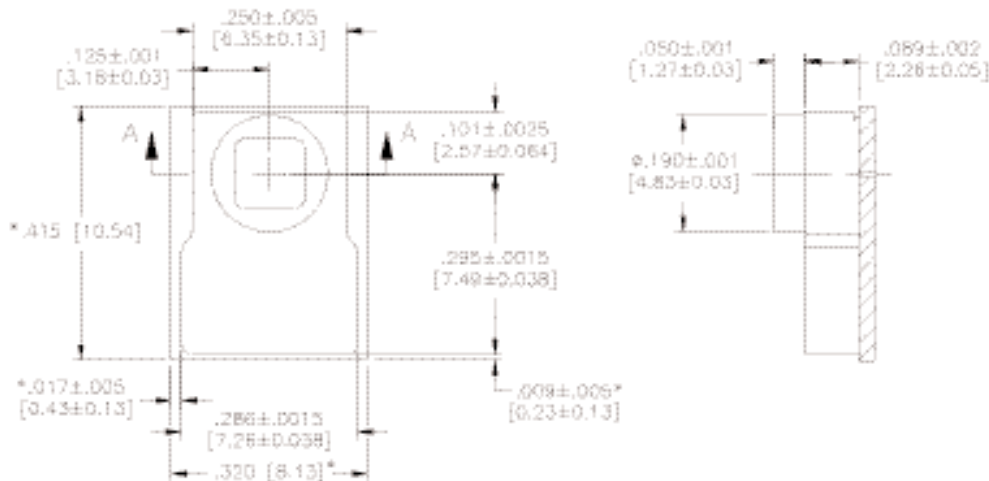

* Dimensions indicated do not include flares.

SECTION A-A

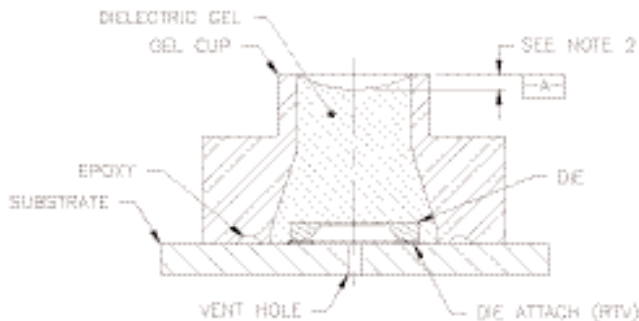

Notes

- Materials Used:**
 Substrate: 98% Alumina
 Transducer (Die): Silicon
 Die Attach Adhesive: Room Temperature Vulcanizer
 Lid Adhesive: Medical Grade UV Curing Adhesive
 Conductor And Contact Pads: Platinum-Silver Alloy
 Wire Bonds And Bond Pads: Gold
 Resistors: Ruthenium-Based Thick Film Paste
 Solder Dams: Green Glass
 Protective Gel Lid: Rad-Stable Polycarbonate Resin
- Miscellaneous of Gel:**
 Max dimension below surface A = $.035^*$ [0.89].
 Max dimension above surface A = $.000^*$ [0.000].
- All dimensions taken at maximum draft.
- All unspecified fillets and radii are $.015^*$ [0.38].
- All draft angles 1° maximum.

measurement
SPECIALTIES

Model 1620 Pressure Sensor

shipping information - 120 UP Snapstrate

All dimensions are in inches (millimeters).

STANDARD PAD CONFIGURATIONS

All dimensions are in inches [millimeters].

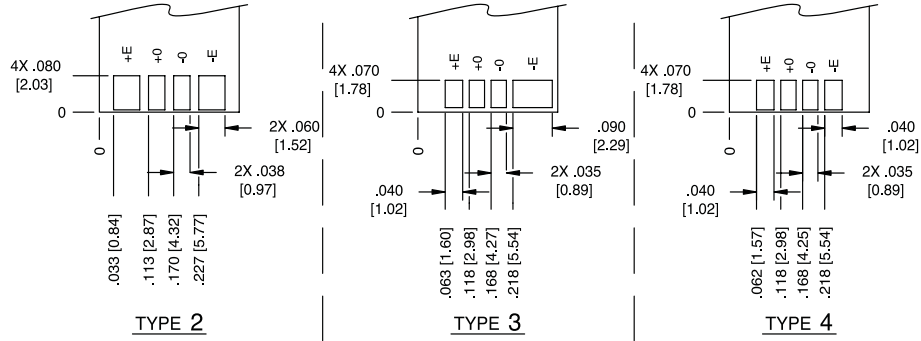

Note

1. Custom pad configurations not show here maybe special ordered. Call Measurement Specialties for details.

SHIPPING INFORMATION

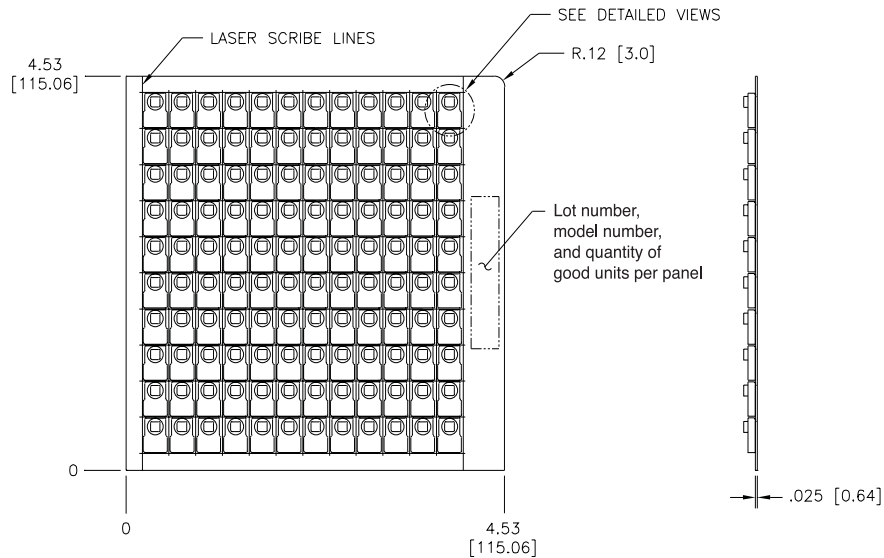

Notes

1. Sensors are shipped as 120 UP snapstrates and must be singulated by the purchaser.
2. Each place may include units that have failed visual or electrical parameters as well as good units. Bad units are identified with a dot on the backside of the cell location.
3. Plates are shipped in dust free anti-static containers to prevent contamination of the gel surface.

SCHEMATIC DIAGRAM

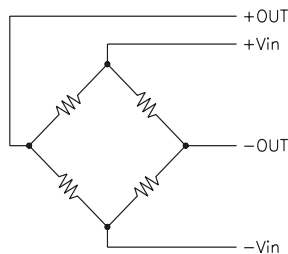

ORDERING INFORMATION

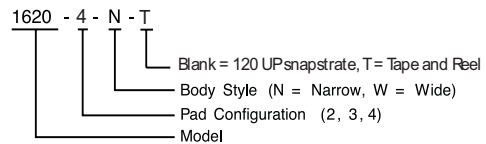

Model 1620 Pressure Sensor

shipping information - Tape and Reel

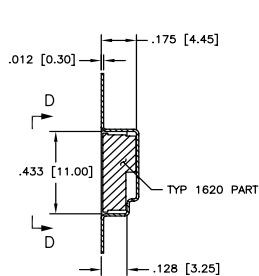
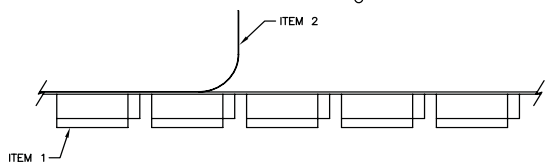
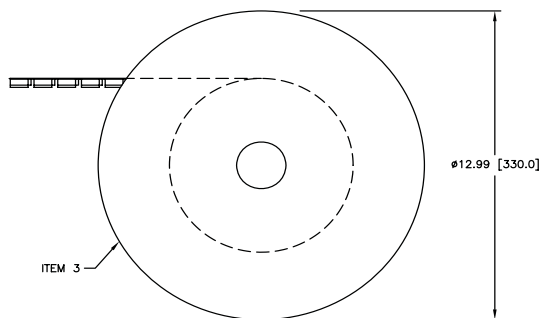
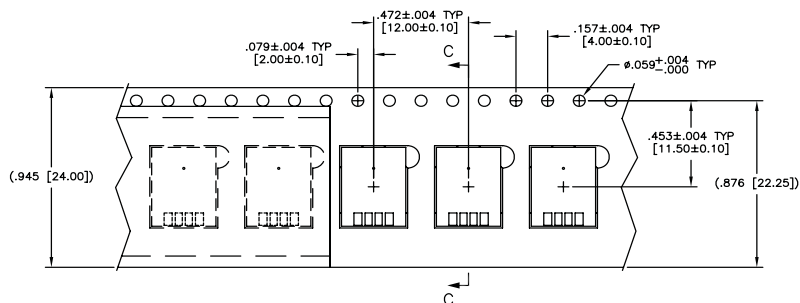

SECTION C-C
SCALE: 2X

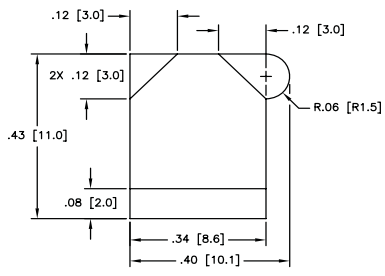

VIEW D-D
SCALE: 4X
SHOWN WITHOUT PART
FOR CLARITY

Notes:

1. MATERIAL: ITEM 1, CARRIER TAPE: POLYCARBONATE
ITEM 2, COVER TAPE: POLYCARBONATE, HEAT PRESSURE SEAL
ITEM 3, PACKAGING TRAY: PLASTIC
2. TOTAL PEEL STRENGTH SHOULD BE 10 TO 130 GRAMS.
3. REFERENCE DOC: ANSI/EIA-481-C: 8mm THROUGH 200mm
EMBOSSSED CARRIER TAPING, 8mm AND 12mm PUNCHED
CARRIER TAPING OF SURFACE MOUNT COMPONENTS FOR
AUTOMATIC HANDLING.

Distribuidor

Brasil e América do Sul

CONTATO

Endereço

Rua Sete de Setembro, 2671 - Centro
13560-181 - São Carlos - SP - Brasil

Telefone

+55 (16) 3371-0112

Fax

+55 (16) 3372-7800

Internet

www.metrolog.net
metrolog@metrolog.net

