

# Inclinometer D-Series

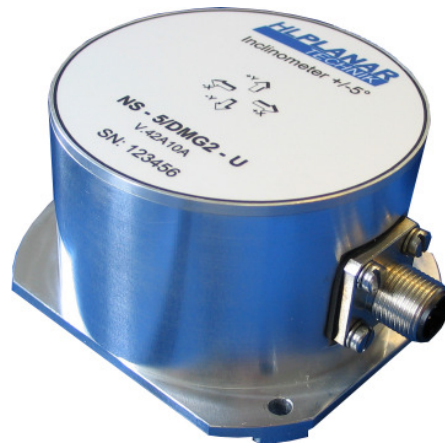

---

HL-Planartechnik GmbH  
Hauert 13  
44227 Dortmund  
Germany

## Table of Contents

<b>1.</b>	<b>Introduction</b>	<b>3</b>
<b>2.</b>	<b>Notice</b>	<b>3</b>
<b>3.</b>	<b>General to the inclinometer system</b>	<b>4</b>
<b>3.1</b>	<b>Description of the measurement principle</b>	<b>4</b>
<b>3.2</b>	<b>Types und Article numbers</b>	<b>5</b>
<b>3.3</b>	<b>Accessories</b>	<b>5</b>
<b>4.</b>	<b>Product specification</b>	<b>6</b>
<b>4.1</b>	<b>Maximum values</b>	<b>6</b>
<b>4.2</b>	<b>Short-time operation overview</b>	<b>6</b>
<b>5.</b>	<b>Dimensions / Installation Instruction/ Connection Specification</b>	<b>7</b>
<b>5.1</b>	<b>Dimensions</b>	<b>7</b>
<b>5.2</b>	<b>Mounting and Installation Instruction</b>	<b>8</b>
<b>5.3</b>	<b>Installation</b>	<b>8</b>
<b>5.4</b>	<b>Measurement</b>	<b>8</b>
<b>5.5</b>	<b>Reference Level</b>	<b>9</b>
<b>5.6</b>	<b>Pin Assignment</b>	<b>10</b>
<b>6.</b>	<b>Serial Interface RS 232</b>	<b>11</b>
<b>7.</b>	<b>Programming Instructions</b>	<b>11</b>
<b>7.1</b>	<b>Basic Settings</b>	<b>11</b>
<b>7.2</b>	<b>Commands in user level</b>	<b>13</b>
<b>8.</b>	<b>Setup Level</b>	<b>14</b>
<b>8.1</b>	<b>Example for setting the output rate</b>	<b>17</b>
<b>9.</b>	<b>Standards</b>	<b>17</b>
<b>10.</b>	<b>Packaging for Delivery</b>	<b>18</b>
<b>11.</b>	<b>Definitions and Disclaimers</b>	<b>18</b>
<b>12.</b>	<b>Additional Information</b>	<b>18</b>

## 1. Introduction

Thank you for your trust in product of company HL Planartechnik GmbH.

This manual offers information on the installation of all Inclinometers of the D-Series.

In addition to this manual you may obtain a substantial Specification with all technical parameters of this inclinometers series.

## 2. Notice



Please observe the general valid rules and regulations regarding the installation of electrical devices when installing this inclinometer.

The inclinometer may not be installed while energized.

Mechanical pressure or stress on the housing must be avoided.

Do not operate the inclinometers above the given maximum values/thresholds. Serious damage to the inclinometer might occur otherwise.

Please observe the maximum tolerable fastening torque for the attachment screws to the aluminium base plate. By applying an excessive fastening torque the aluminium base plate might be drafted. This would cause a loss of warranty of a proper and faultless operation.

For cleaning of the housing only use detergents free of alcohol or acid.

Avoid direct solar radiation.

Please apply connector plug to inclinometer only hand-screwed.

If any disturbances of operation occur although the inclinometer was operated according to this manual, only countermeasures may be applied that are proposed by this manual. Do not apply any other measures, as damage to the inclinometer might be caused. An opening of the inclinometer is not possible. Please contact our service team.

### 3. General to the inclinometer system

#### 3.1 Description of the measurement principle

Platinum electrodes are deposited in pairs on the base of the sensor's cell parallel to the sensitive axis. The chamber is partially filled with an electrolytic liquid. When an alternating voltage is passed between two electrodes, the electric current will create a dispersed field. By tilting the sensor and thereby reducing the level of liquid, it is possible to confine this stray field. Because of the constant, specific conductivity of the electrolytes a variance of resistance is formed in relation to the liquid level. A basic differential principle will yield an angle of inclination from the polarity signs.

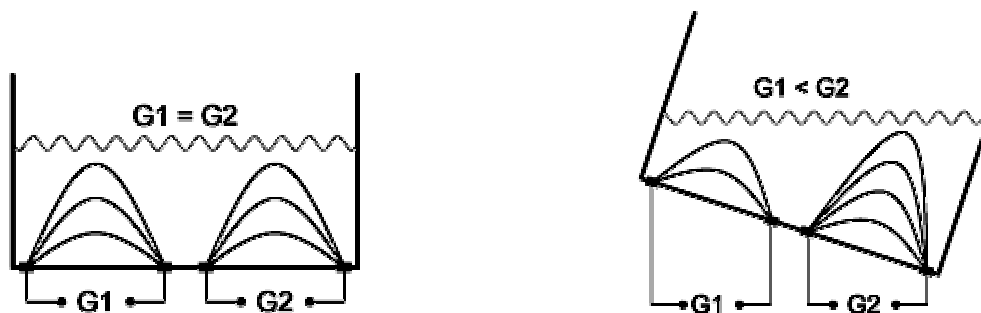

Fig. 3.1.1 Conductometric inclination measurement

### 3.2 Types und Article numbers

HL Planartechnik offers inclinometers in the three different measurement ranges  $\pm 5^\circ$ ,  $\pm 15^\circ$  und  $\pm 30^\circ$  with different output signals.

Type	Meas. Range	Output	Article no.
NS - 5/DMG2 - U	$\pm 5^\circ$	RS 232, U 0...4,5V	2.000.592.146.000
NS - 5/DMG2 - I	$\pm 5^\circ$	RS 232, I 4...20 mA	2.000.592.166.000
NS - 5/DMG2 - PWM	$\pm 5^\circ$	RS 232, PWM 1kHz, 20....80%	2.000.592.136.000
NS - 5/DMG2 - S	$\pm 5^\circ$	RS 232, switch	2.000.592.156.000
NS - 15/DMG2 - U	$\pm 15^\circ$	RS 232, U 0...4,5V	2.001.592.146.000
NS - 15/DMG2 - I	$\pm 15^\circ$	RS 232, I 4...20 mA	2.001.592.166.000
NS - 15/DMG2 - PWM	$\pm 15^\circ$	RS 232, PWM 1kHz, 20....80%	2.001.592.136.000
NS - 15/DMG2 - S	$\pm 15^\circ$	RS 232, switch	2.001.592.156.000
NS-30/DMG2 -U	$\pm 30^\circ$	RS 232, U 0...4,5V	2.003.092.146.000
NS-30/DMG2 -I	$\pm 30^\circ$	RS 232, I 4...20 mA	2.003.092.166.000
NS-30/DMG2 -PWM	$\pm 30^\circ$	RS 232, PWM 1kHz, 20....80%	2.003.092.136.000
NS-30/DMG2 - S	$\pm 30^\circ$	RS 232, switch	2.003.092.156.000

### 3.3 Accessories

The inclinometer will generally be delivered without connector cables.

A connector cable or plug is optionally available.

Female cable connector Binder Series 763 (M12x1):

Straight type Article No.: 2.000.000.000.005

Angled type Article No.: 2.000.000.000.006

Standard cable length 2m, single sided plug:

Straight type Article-No.: 2.000.000.000.001

Angled type Article-No.: 2.000.000.000.002

Special length on request.

## 4. Product specification

### 4.1 Maximum values

Parameter	Symbol	Conditions	Min	Typ	Max	Unit
Supply Voltage	Ub	Measurement of Ub against GND, reverse polarity protection	-30		+30	V
Signal Voltage	UXout UYout	When used as switch, measured against SGND	0		100	V
Isolation Signal Voltage Circuit		When used as switch, measured UXOut, UYOut, SGND against all other connections	-125		+125	V
Switch current	IXout IYout	Xout, Yout to SGND			50	mA
Storage Temperature	Tstor		-55		+85	°C
Inclination angle in x and y	φmax	Supply voltage is applied. NS – 5/DMG2-x NS – 15/DMG2-x NS – 30/DMG2-x	-15 -40 -60		+15 +40 +60	°

### 4.2 Short-time operation overview

Parameter	Symbol	Conditions	Min	Typ	Max	Unit
Supply Voltage	Ub	Measured Ub against GND	+10	+24	+30	VDC
Operating Temperature	Top	Inclination Sensor Unit	-40		+85°C	°C
Current Consumption	Icc	No load at Output			30	mA
Measurement Range		NS-05/DMG2-xx NS-15/DMG2-xx NS-30/DMG2-xx	- 5 -15 -30		+ 5 +15 +30	°
Resolution	Res	Digital Output RS 232		0.001		°
Accuracy	D1-Acc1	Digital Output RS 232 [Top=25°C] NS – 5/DMG2- U,I,PWM, S		0.03		°
Accuracy	A1-Acc1	Analog Output [Top=25°C] NS – 5/DMG2- U,I,PWM, S		0.04		°
Accuracy	D2-Acc1	Digital Output RS 232 [Top=25°C] NS – 15/DMG2- U,I,PWM, S		0.1		°
Accuracy	A2-Acc1	Analog Output [Top=25°C] NS – 15/DMG2- U,I,PWM, S		0.15		°
Accuracy	D3-Acc1	Digital Output RS 232 [Top=25°C] NS – 30/DMG2- U,I,PWM, S		0.3		°
Accuracy	A3-Acc1	Analog Output [Top=25°C] NS – 30/DMG2- U,I,PWM, S		0.4		°
Voltage Output	Ua	Inclination angle x,y = 5°,15°,30° - x,y°... + x,y°	0,5		4.5	V
Current output	Ia	Inclination angle x,y = 5°,15°,30° - x,y°... + x,y°	4		20	mA
PWM Output	PWMA	Winkelbereich x,y = 5°,15°,30° - x,y°... + x,y° f <sub>PWM</sub> = 1 kHz	20		80	%
Switch Output	Sa	inclination angle x,y = 5°,15°,30° - x,y°... + x,y°, Step 0.1°		0.1		°

## 5. Dimensions / Installation Instruction/ Connection Specification

### 5.1 Dimensions

The dimensions of the different inclinometer types of the D-Series are identical.

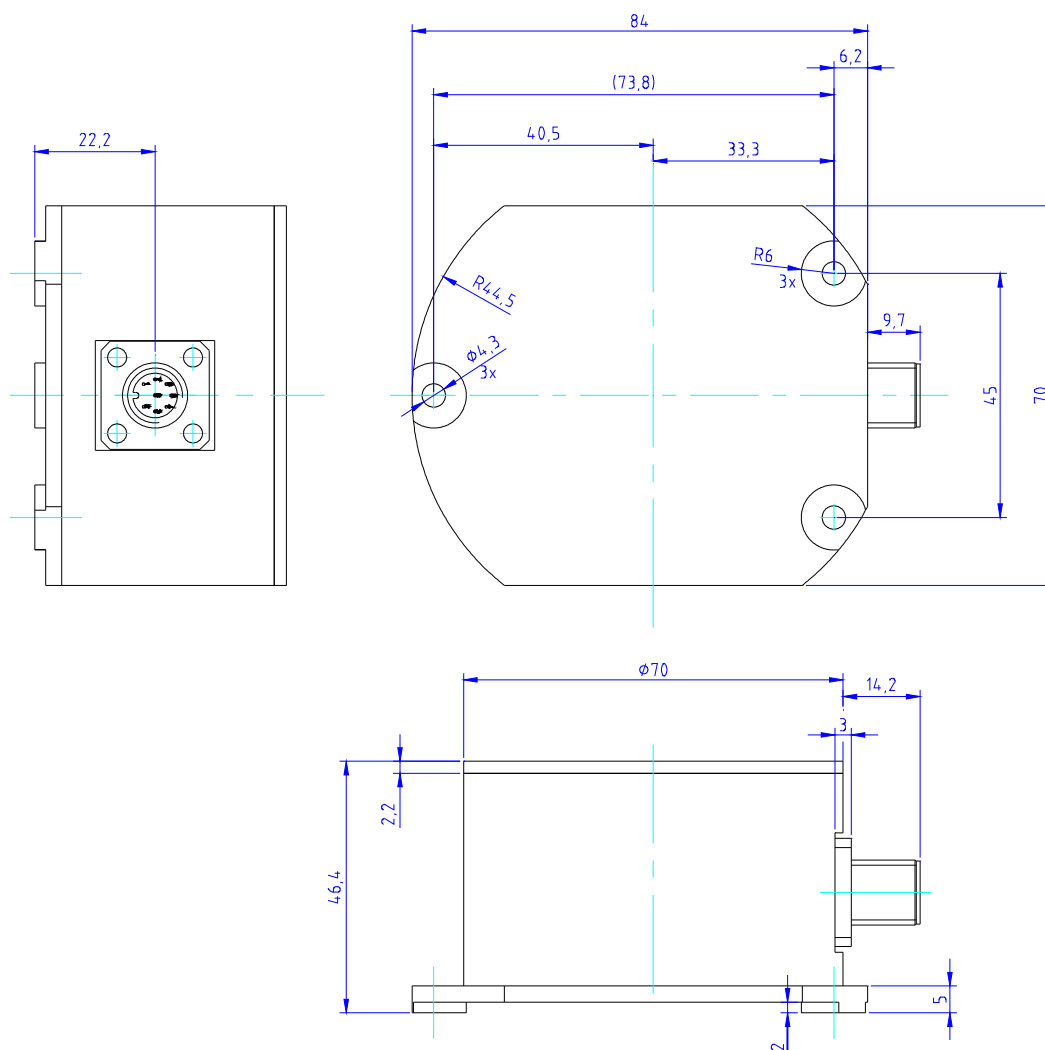

Fig. 5.1.1 View of the inclinometer's housing

## 5.2 Mounting and Installation Instruction

The inclinometer is designed for a horizontal mounting, i.e. the base plate of the inclinometer with the three mounting holes needs to be placed on the horizontal plane of the object to be measured. It can be mounted with M4 screw as a maximum.

The mounting surface must be plane and free of dust and grease.

We recommend cheese head screws with metrical thread M4 for the mounting.

Maximum fastening torque for the mounting screws is 10 Nm.

## 5.3 Installation

Prior to installation, please check for all connection and mounting instructions to be complied with. Please also observe the general rules and regulations on low voltage technical devices.

Avoid shock and vibration during measurement, as these could corrupt the measurement results. Inclination sensors that base on a fluidic measurement principle are optimal for static measurements and suitable to only a limited extent of dynamic measurement.

## 5.4 Measurement

The measurement of the tilt angle of the single measurement axis is carried out over the respective longitudinal and lateral axis of the inclination sensor. Reference is always the horizontal plane.

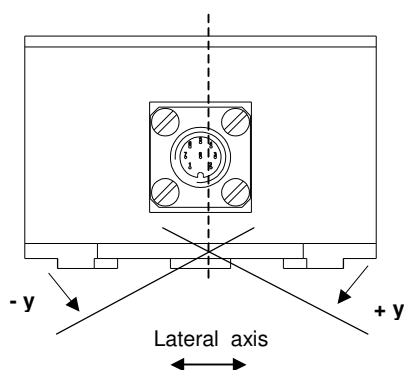

Fig. 5.3.1 View of male socket

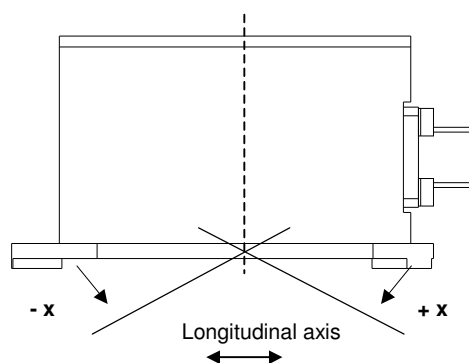

Fig. 5.3.2 Side view

### 5.5 Reference Level

The Inclinator has a mounting reference angle (black line) for an optimal mounting of the inclinometer, which is parallel to the x-axis. This reference angle must be placed exactly parallel to the object to be measured to prevent or minimize any mechanical offset/cross sensitivity.

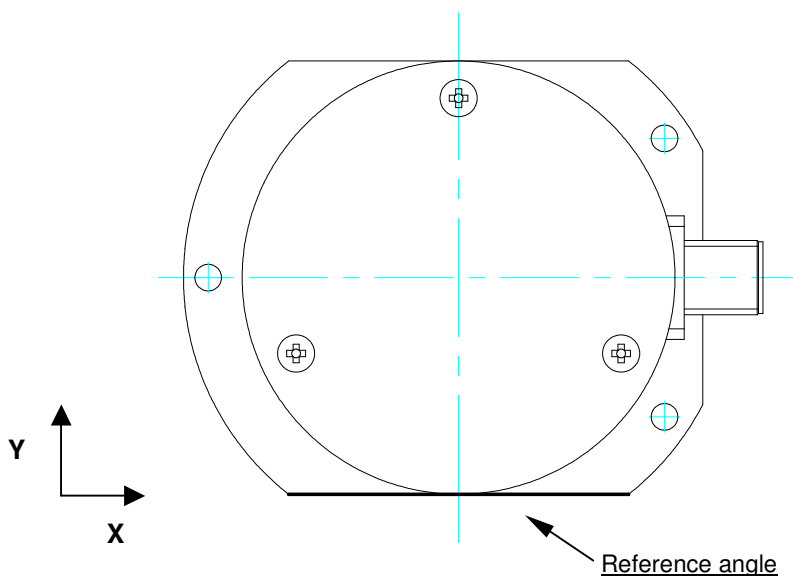

Fig. 5.4.1 Reference angle of the inclinometer, top view.

## 5.6 Pin Assignment

The pin assignment of the pin socket is as follows

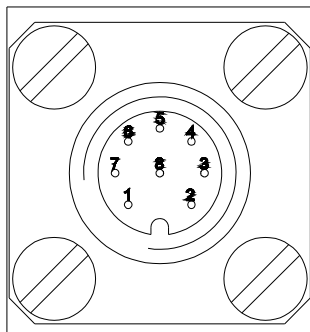

Fig. 5.5.1  
Front view of housing connector  
inclinometer

Pin	Name	Description	Type	Colour scheme <sup>(1)</sup>
1	+Ub	positive power supply +10...+30VDC	supply	white
2	RxD	Rx serial signal RS 232	input	brown
3	TxD	Tx serial signal RS232	output	green
4	GND	ground	supply	yellow
5	XOut	X-axis output <sup>(2)</sup>	output	grey
6	SGND	signal ground	supply	pink
7	YOut	Y- axis output <sup>(2)</sup>	output	blue
8	NC	NC	n.c.	red

(1) by using the standard cable of HL Planartechnik GmbH.

(2) dependent of inclinometer version:

NS-xx/DMG2-U	output signal (X,Y) analog voltage 0.5...4.5V
NS-xx/DMG2-I	output signal (X,Y) analog current 4...20mA
NS-xx/DMG2-PWM	output signal (X,Y) PWM 1kHz, 20...80%
NS-xx/DMG2-S	output signal (X,Y) switch , 0.1° step

## **6. Serial Interface RS 232**

Communication with the sensor is done through a standardized RS-232 interface. Data transmission is effected in duplex mode. The baud rate is fixed by 9600 baud.

After Power On the sensor is sending continuous the angle values in degrees (°).

In the setup level several settings can be permanently modified.

If the continuous mode was permanently changed to the polling mode, the sensor will send after "Power On" a start information with actual parameters.

On error no angle values are sending and after "Power On" a error message was add to the start information.

## **7. Programming Instructions**

### **7.1 Basic Settings**

After Power On, the sensor is in the user level.

In factory setting (==Free running mode) every 100ms the current angle values are continuously supplied with a baud rate of 9600 bd.

In the Setup-level several settings can be changed permanent like query or free running mode, output rate, baud rate and angle offset.

If query mode instead of free running mode is ser, the sensor will send start information with the current settings after Power On.

In case of errors no angle values will be provided and after Power On an error message will be added to the start information.

Interface parameter:

- 9600 Baud , 8 data bits, parity even, 1 stop bit,

The baud rate can be adjusted to different values in the Setup-level.

## Structure:

Baud rate: 9600 Baud (factory setting, changes in Setup-Mode possible)

Format: ASCII, 8 data bits, 1 stop bit, parity even

Length: 22 byte

Display: <D0 ... D21>

D0 ... D10 = "X=±xx.xxx", <CR>, <LF>

with D2 = sign (+ or -)  
with D5 = point

D11 ... D21 = "Y=±xx.xxx", <CR>, <LF>

with D13 = sign (+ or -)  
with D16 = point

display example:

```
...  
X=+00.430  
Y=-00.084  
...
```

## 7.2 Commands in user level

**Table 1: instructions at user level**

instruction	to the sensor	response sensor	explanation
activate temporary polling mode (1) (2)	"f"	"f"	the continuous sending of angle values are stopped, instructions can send to the sensor
activate temporary continuous mode (1) (2)	"F"	"X=±xx.xxx", CR, LF, "Y=±xx.xxx", CR, LF, "X= . . ."	X angle in ° Y angle in ° with „±“ = „+“ or „-“, one string contains x and y value
read angle values at one-time (3)	"R"	"X=±xx.xxx", CR, LF, "Y=±xx.xxx", CR, LF,	X angle in ° Y angle in ° with „±“ = „+“ or „-“
switch to the setup level (3) (4)	"prog"	"P"	Sensor is at setup level
show active level (3)	"**"	"Ux" or "Sx"	„U“ means Sensor is at User level „S“ means Setup-level is active, with „x“ Output-Mode of Sensors „U“ / „I“ / „P“ / „S“

- (1) In free running mode measurement data is continuously displayed. In query mode measurement and display is only once on command.
- (2) After reset or new Power On after an interruption of power supply, the sensor will be in user-level again with the original setup or with the setup changed in the setup level.
- (3) Only possible in query mode (=free running mode deactivated).
- (4) The Input of „prog“ must take place within 20 sec.

## 8. Setup Level

The Setup level is active until "Power On" or Reset. All settings taken in the setup level are stored in the EEPROM and permanent available also after Power down.

**Table 2: instructions at setup level**

instruction	to the sensor	response sensor	explanation
activate permanent polling mode (1)	"f"	"f"	the continuous sending of angle values are permanent stopped, instructions can send to the sensor
activate permanent continuous mode (1)	"F"	"X=±xx.xxx", CR, LF, "Y=±xx.xxx", CR, LF, "X= . . .	continuous sending of X angle in ° Y angle in ° with „±“ = „+“ or „-“
set rate of data transmission for continuous mode (2) (3) (4)	"O" <Code transmission rate>	"O" <Code transmission rate>	Echo, Code transmission rate or „E“ for Error, if the code is outside defined values
read angle values at one-time (2)	"R"		same as at user level
read version (2)	"V"	"NS-xx/DMG2-x", CR, LF "SN:xxxxxxx", CR, LF "HV:xx.x", CR, LF "SV:xx.x", CR, LF	type of Sensor serial number HW Version internal sensor SW Version
offset adjust of the specified axis (2) (3)	"n" "x" or "y"	"n" "OffsetX=±xx.xxx" or "OffsetY=±xx.xxx"	the actual angle of specified axis is set to zero, ±xx.xxx is the internal offset in degree
reset offset adjust (2) (3)	"N"	"N"	the offset adjust was reset to the original value
Set Baud rate (2) (3) (5)	"B" <Code Baud rate>	"B" <Code Baud rate>	Echo, Code Baud rate or „E“ for Error, if the code is outside defined values
Set switch angle for one axis (2) (3) (6) (7)	"Sx" <switch angle> or "Sy" <switch angle>	"Sx" or "Sy" <switch angle>	Echo, switch angle or „E“ for Error, if the angle is outside admissible range
Set hysteresis for switching point in both axis (2) (3) (6) (8)	"Sh" <hysterese>	"Sh" <hysterese>	Echo, hysterese or „E“ for Error, if the angle is outside admissible range
show active level (2)	"**"		same as at user level
Reset (2)	"q"	"q"	Software-Reset will be executed

- (1) in the continuous mode the sensor is sending continuous angle values, in the polling mode the sensor is sending one answer after an instruction
- (2) only possible at polling mode.
- (3) for activating a reset or power fail restart is necessary
- (4) for Code transmission rate see Table 3 <Code transmission rate >
- (5) for Code baud rate see Table 4 <Code Baud rate>  
Attention! A reset of the baud rate to a default value is not possible. If the user forgets the adjusted baud rate, the new value must be detected by testing.
- (6) this instruction is only effectual at sensors with switch output,
- (7) <switch angle>: three digits from "001" until "300" for the angle in tenths of a degree, max working range of the sensor. Default value is 025 == 2,5°
- (8) <hysteresis>: two digits from "01" until "99" for the stitching hysteresis in tenths of a degree, max working range of the sensor , Default value is 01 == 0,1°

**Table 3 <Code transmission rate >**

<b>&lt;Code transmission rate &gt;</b>	<b>strings per second, 1 string contains x and y-value</b>
"0"	reserved
"1"	25 Strings/s (9)
"2"	10 Strings/s, Default value (10)
"3"	5 Strings/s
"4"	2 Strings/s
"5"	1 Strings/s
"6"	0,2 Strings/s
"7"	0,1 Strings/s
"8", "9"	not defined

(9) only allowed with baud rate of at least 9600 Bd

(10) only allowed with baud rate of at least 4800 Bd

**Table 4 <Code Baud rate>**

<b>&lt;Code Baud rate&gt;</b>	<b>baud rate</b>
"0"	2400 Baud
"1"	4800 Baud
"2"	9600 Baud, Default value
"3"	19200 Baud
"4"	38400 Baud
"5"	57600 Baud
"6", "7", "8", "9"	not defined

### 8.1 Example for setting the output rate

In the following example the output rate is set to 1 string per second

instruction	to the sensor	response sensor	explanation
		„X=±xx.xxx“, CR, LF, „Y=±xx.xxx“, CR, LF, „X= . . .	continuous sending of angles
activate temporary polling mode	”f”	“f”	the continuous sending of angle values are stopped, instructions can send to the sensor
switch to the setup level	”prog”	”P”	Sensor is at setup level
set rate of data transmission for continuous mode	“O5”	“O5”	Code transmission rate is set to 1Strings/s
Reset	“q”	“q”	Software-Reset will be executed, the new settings are guilty
		„X=±xx.xxx“, CR, LF, „Y=±xx.xxx“, CR, LF, „X= . . .	continuous sending of angles at 1 Strings/s

## 9. Standards

- IEC/EN 61000-6-4                      EMC – emitted interference industry
- IEC/EN 61000-6-2                      EMV – interference resistance industry
- IEC/EN60068-2-27                      Mechanical shock test
- IEC/EN60068-2-6                        Vibration loading
- IEC/EN 60068-2-14                      Thermo shock
- DIN EN 60068-2-78                      Damp heat, steady state
- DIN 40050-9                                Spraying water, protection class IP 67

## 10. Packaging for Delivery

Safe single package "Blitz Versandbox", company "Ratioform", type CVB (150x110x67 mm, for one piece) type will be used for the delivery of the product.

## 11. Definitions and Disclaimers

- Application information – Applications that are described herein for any of these products are for illustrative purpose only. HL Planartechnik GmbH makes no representation or warranty that such applications will be suitable for the specified use without further testing or modification.
- Life support applications – These products are not designed for use in life support appliances, devices, or systems where malfunctions of these products can reasonably be expected to result in personal injury. HL Planartechnik GmbH disclaims any financial responsibility for the misuse of its products by the customer that result in personal injury.
- Right to make changes – HL Planartechnik GmbH reserves the right to make changes in the products, without notice. Products include circuits, standard cells and/or software, described or contained herein in order to improve design and/or performance. HL Planartechnik GmbH assumes no responsibility or liability for the use of any of these products, conveys no license or title under any patent, copyright, or prototype right to these products, and makes no representations or warranties that these products are free from patent, copyright, or prototype right infringement, unless otherwise specified.

## 12. Additional Information

Manufacturer company: HL-Planartechnik GmbH  
Hauert 13  
D-44227 Dortmund  
Phone: +49 (0)231/ 9740-0  
Fax: +49 (0)231/ 9740-20  
URL: [www.hlplanar.de](http://www.hlplanar.de)  
Mail: <mailto:service@hlplanar.de>

# Distribuidor

Brasil e América do Sul

## CONTATO

### Endereço

Rua Sete de Setembro, 2671 - Centro  
13560-181 - São Carlos - SP - Brasil

### Telefone

+55 (16) 3371-0112

### Fax

+55 (16) 3372-7800

### Internet

[www.metrolog.net](http://www.metrolog.net)  
[metrolog@metrolog.net](mailto:metrolog@metrolog.net)

