

# MP2000 Series

## The Schaevitz® microprocessor based LVDT indicator

and set-point controller is designed for industrial and process control applications utilizing any LVDT/RVDT-based measurement device. In addition to displaying real-time readings of LVDTs, RVDTs and gage heads, the MP2000 also displays MIN, MAX, TIR, A+B and A-B values. Programmable, opto-isolated, open collector setpoints may be assigned to any of the above functions.

A 17-bit analog-to-digital converter provides excellent performance and resolution. A new standard 9-pin RS-232 pin-out provides serial data output to a PLC or PC com port.

MP Series readout/ controllers are packaged in a 1/4 DIN aluminum case with a EL back-lit, bit-mapped LCD display. (Units are splash-proof when mounted with a gasket.)

### Set-point Control

Four user-programmable digital setpoints are used to monitor any display parameter. Any combination of high or low setpoints may be selected. User programmable, high and low hysteresis values may be used to create set-point dead band, for prevention of control relay chatter. Each channel decimal point is individually programmable, via the set-up menu.

### Auto-Calibration

A front panel pushbutton auto-zeros (tares) over the  $\pm$  full scale range. Auto-calibration eliminates calculation of slope or gain factors. Calibration and setup parameters are stored in nonvolatile memory for retention on power down or interruption.

### Readings

A large, easy to read, bit-mapped display provides user-friendly, menu driven prompts for simple push-button system setup, calibration and monitoring of in-process measurement parameters.

- Current value
- min/max
- A+B (sum of two channels)
- A-B (difference between two channels)
- TIR (Total Indicated Run-out)

### Outputs

A real-time scaled analog output, proportional to the digital readout is provided for each LVDT channel. An RS-232 output is provided for data transfer to a computer at 1200 to 19.2K baud.

## FEATURES

- Large 10 mm High Display Characters
- Software Set-Up Menu
- Industry Standard 9-Pin RS-232 Connector
- Greatly Enhanced Long-Term Reliability
- Rugged DIN Style Power Supply Connector
- Two Channels for the Price of One

## APPLICATIONS

- LVDT-Based Weighting Systems
- Pass/Fail Part Sorting
- Roller Gap Control
- Concentricity Gaging
- Press Cycle Control
- Part Classification



## dimensions

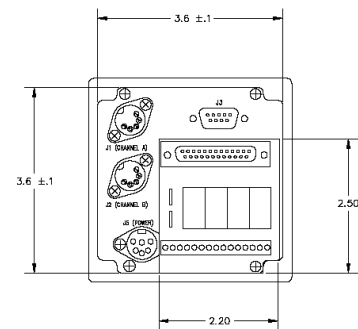
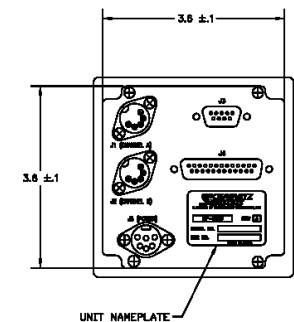
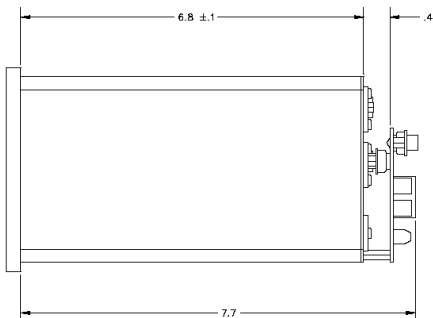

NOTE: shown with optional relay card

# MP2000 Series

## Specifications and Features

LVDT Excitation Voltage	1 and 3 rms
LVDT Drive Current	Up to 25 mA rms per LVDT
Excitation Frequency	2.5, 3.3, 5, and 10 kHz (+/- 5%)
Input Sensitivity	0.6 or 1.2 V rms for full scale readout
Input Impedance	>100k ohms
Linearity	≤ +/- 0.02% of full scale
Digital Display	5 digit +/- 99.999 10 mm (0.4") high bitmapped LCD with EL Backlight
Analog Outputs	+/- 5 or 0 to 10 Vdc
Set-Points	4 user-programmable, high or low with on-board LED indicators
Set-Point Hysteresis	User Programmable
Set-Point Outputs	Opto-isolated open collector logic outputs, 5 VDC, 4 mA per set-point
Response	Typically within 20ms
Operating Temperature	0 to 55C
Power Requirements	100 to 240 VAC, 47 to 63 Hz

### connections

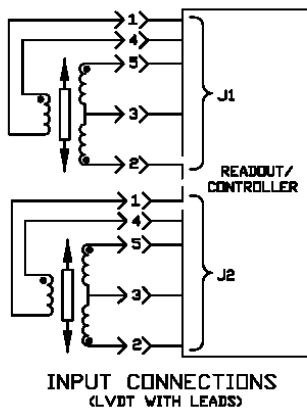

#### PIN OUT CONNECTIONS (J3)

PIN	PIN
1 -	5 - DIG GND
2 - TxD	6 - DTR
3 - RxD	7 -
4 - DSR	8 -
	9 -

#### PIN OUT CONNECTIONS (J4)

PIN	PIN
1 - SETPOINT #4	14 - REMOTE ZERO
2 - DSR	15 - SETPOINT #3
3 - TxD	16 - SETPOINT #2
4 - DTR	17 - SETPOINT #1
5 - RxD	18 - SP RETURN
6 -	19 - REMOTE RESET
7 - SYNC INPUT	20 - OUTPUT CHAN B
8 - SYNC OUTPUT	21 - OUTPUT CHAN A
9 -	22 -
10 -	23 - Vcc (5VDC)
11 -	24 - DIG GND
12 -	25 - ANALOG GND
13 -	

### accessories

- Relay Option Board
- Lab Stand/ Bench Mount
- 4-Up Rack Adaptor (bottom)

The information in this sheet has been carefully reviewed and is believed to be accurate; however, no responsibility is assumed for inaccuracies. Furthermore, this information does not convey to the purchaser of such devices any license under the patent rights to the manufacturer. Measurement Specialties, Inc. reserves the right to make changes without further notice to any product herein. Measurement Specialties, Inc. makes no warranty, representation or guarantee regarding the suitability of its product for any particular purpose, nor does Measurement Specialties, Inc. assume any liability arising out of the application or use of any product or circuit and specifically disclaims any and all liability, including without limitation consequential or incidental damages. Typical parameters can and do vary in different applications. All operating parameters must be validated for each customer application by customer's technical experts. Measurement Specialties, Inc. does not convey any license under its patent rights nor the rights of others.

### ordering info

Model: MP-2000  
P/N: 02291335-000

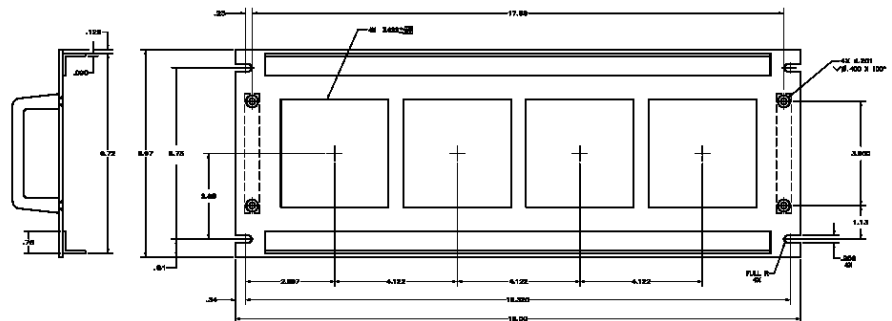

### CONTATO

#### Endereço

Rua Sete de Setembro, 2671 - Centro  
13560-181 - São Carlos - SP - Brasil

#### Telefone

+ 55 (16) 3371-0112

#### Fax

+ 55 (16) 3372-7800

#### Internet

[www.metrolog.net](http://www.metrolog.net)  
[metrolog@metrolog.net](mailto:metrolog@metrolog.net)



Metrolog Controles de Medição