

DT Series Elements

The DT series of piezo film sensors elements are rectangular elements of piezo film with silver ink screen printed electrodes. They are available in a variety of different sizes and thicknesses.

DT elements are supplied with a thin urethane coating over the active sensor area; the lead attachment legs are free of the insulating urethane coating.

The DT film element produces more than 10 millivolts per microstrain, about 60 dB higher than the voltage output of a foil strain gage. The capacitance is proportional to the area and inversely proportional to the thickness of the element.

The DT series sensors are the simplest form of piezo film sensors, used primarily as dynamic strain gages and contact microphones for vibration or impact detection. These are available without any leads for those applications where the customer wants to make his own lead attachment. They can be readily adhered to a surface with double-sided tape or epoxy. Lead attachment can be achieved by compressive clamping, crimps, eyelets, conductive epoxy or low temperature solders.

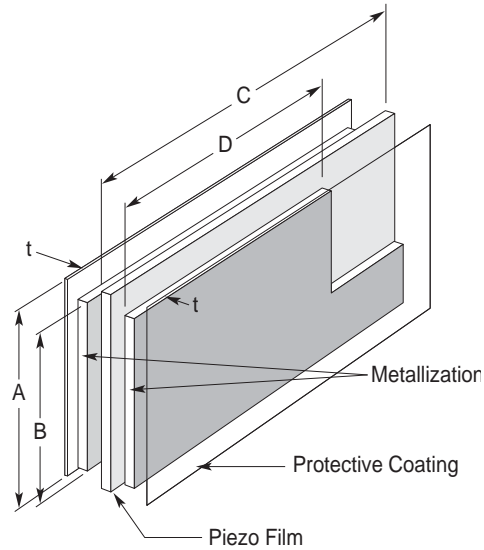

DIMENSIONS in INCHES (mm)

Description	A Film	B Electrode	C Film	D Electrode	t (μ m)	Cap (nF)	Part Number	Low Volume Price (US \$)
DT1-028K	.64 (16)	.484 (12)	1.63 (41)	1.19 (30)	40	1.38	1-1002608-0	2.00
DT1-052K	.64 (16)	.484 (12)	1.63 (41)	1.19 (30)	64	.740	2-1002608-0	2.25
DT2-028K	.64 (16)	.484 (12)	2.86 (73)	2.42 (62)	40	2.78	1-1002145-0	3.00
DT2-052K	.64 (16)	.484 (12)	2.86 (73)	2.42 (62)	64	1.44	2-1002145-0	4.25
DT4-028K	.86 (22)	.740 (19)	6.72 (171)	6.13 (156)	40	11.00	1-1002149-0	6.00
DT4-052K	.86 (22)	.740 (19)	6.72 (171)	6.13 (156)	64	5.70	2-1002149-0	7.25

Effective: April 1st, 2008

Please contact factory for custom part quotations and volume pricing.

Distribuidor

Brasil e América do Sul

CONTATO

Endereço

Rua Sete de Setembro, 2671 - Centro
13560-181 - São Carlos - SP - Brasil

Telefone

+55 (16) 3371-0112

Fax

+55 (16) 3372-7800

Internet

www.metrolog.net
metrolog@metrolog.net

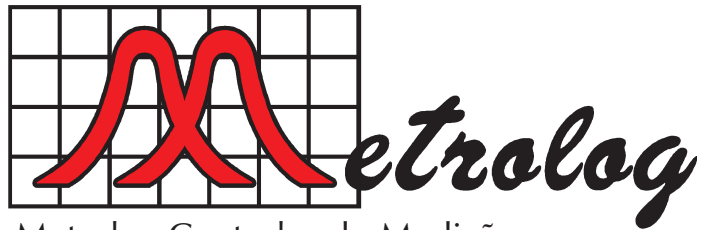

Metrolog Controles de Medição