

# ELPF Load Cell

Compact Tension/Compression Design

Ranges: 10 through 500 lbf

High Level and Millivolt Output

High Stability

Industry Standard Packaging

Resists Off Axis Load Components

Full NIST Traceable 11 Point Calibration

Shielded Teflon Cabling with Strain Relief

## DESCRIPTION

The **ELPF** series tension/compression load cells raise the bar for high performance at low cost. Measurement Specialties proprietary Microfused™ technology, derived from demanding aerospace applications, employs micro-machined piezoresistive strain gages fused with high temperature glass to a high performance stainless steel force measuring flexure. Microfused™ technology eliminates age-sensitive organic epoxies used in traditional load cell designs providing excellent long term span and zero stability. Operating at very low strains, Microfused™ technology utilizes strain gages providing gage factors greater than 100, an essentially unlimited cycle life expectancy, superior resolution,

## FEATURES

- ◆ Low Cost
- ◆ Optional High Level Output
- ◆ Small, Low Profile Design
- ◆ Low Noise
- ◆ Robust: High Overrange
- ◆ High Reliability
- ◆ Low Deflection
- ◆ Low Off-Axis Response
- ◆ Fast
- ◆ Essentially Unlimited Cycle Life

## APPLICATIONS

- ◆ Theatrical Rigging Loads
- ◆ Assembly Forces
- ◆ Weighing
- ◆ Tool Forces
- ◆ Thrust Measurements
- ◆ Batch Weighing
- ◆ Robotics End Effectors
- ◆ Product Validation Testing
- ◆ Medical Instruments
- ◆ Hoist and Winch Loads

PRELIMINARY



exceedingly high overrange capabilities (without the need for stops) and an amplified ratiometric high level 0.5 to 4.5 V output or 20 mV/V bridge output. Microfused™

sensors are ideal for your test and measurement applications.



Measurement Specialties' ELPF Test and Measurement series sensors, unlike most competitive designs, are provided with a "four-bar" design where a flexible diaphragm parallels the measuring flexure. This configuration is far less susceptible to off-axis load components than single diaphragm traditional designs. Shielded, teflon insulated instrumentation cabling is provided along with spring steel strain reliefs and full NIST traceable calibration certificates. The ELPF unit is fully thermally compensated and will provide an essentially unlimited cycle life expectancy. The ELPF can be configured with a variety of options to fine tune the instrument to your application: select from several standard package geometries, compensated temperature ranges, input voltages, lead lengths or specify entirely unique combinations of these options.

## standard performance parameters:

Maximum over load:	250%
Recommended Excitation:	5 Vdc
Output Span (Amplified/Ratiometric):	0.5 to 4.5 V +/-3% of Span at 5 Vdc Excitation
Output span (Bridge Output):	20 mV/V +/- 5%
Output at No Load (Zero Output):	+/- 5% FSO
Nonlinearity:	+/- 0.25% FSO
Hysteresis:	+/- 0.25% FSO
Temperature Compensation	20 -80°C
Thermal Zero Shift	+/- 0.01% FSO/°C
Thermal Sensitivity Shift:	+/- 0.01% /°C
Operating Temperature Range:	-40°C to 120°C
Impedance In (Bridge Only):	3 K ohm nominal
Impedance Out (Bridge Only):	2.2 K ohm nominal
Deflection at Rated Load	< 0.05 mm nominal
Isolation Resistance:	> 50 Megohm nominal at 250 Vdc
Cycle Life Expectancy:	Essentially Unlimited

Note: Positive output in tension.

Note: Re: Zero output: Lower trim values available on request.

Note: Laser welded stainless steel body construction. Spring strain relief and shielded teflon cable provided standard.

Note: Unique 4 bar linkage design provides resistance to off axis load components.

PRELIMINARY

## dimensions

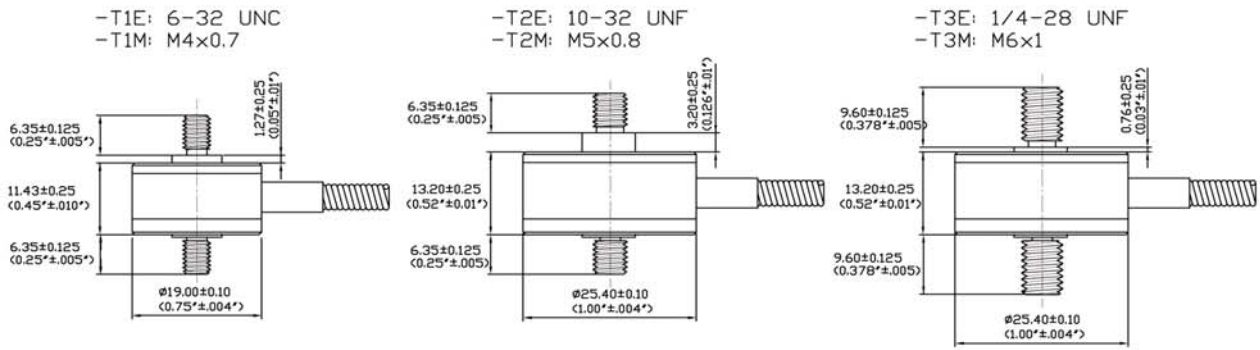

### WIRING

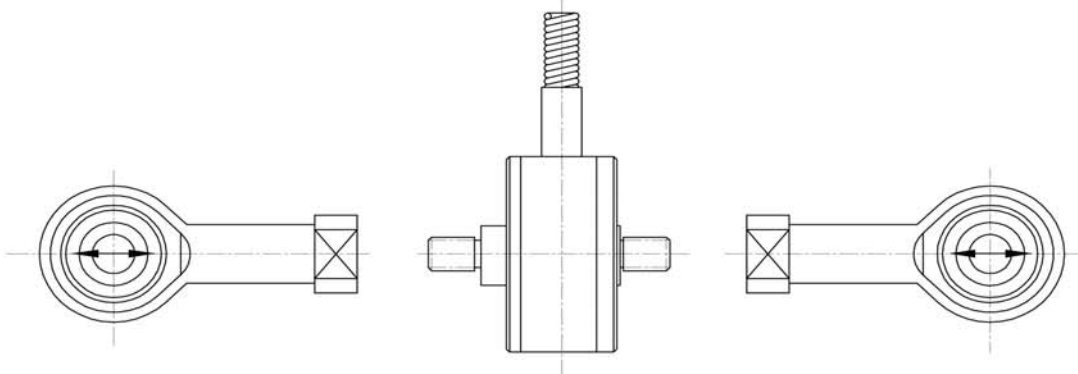
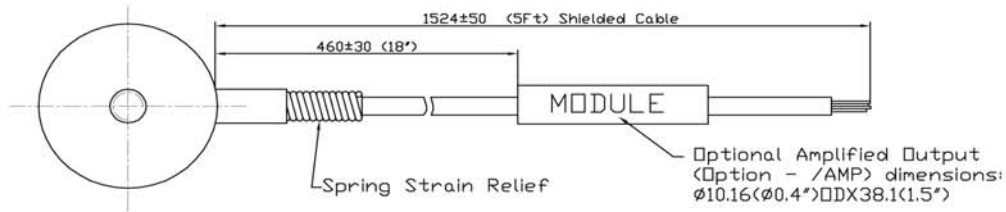

### Millivolt Bridge Version

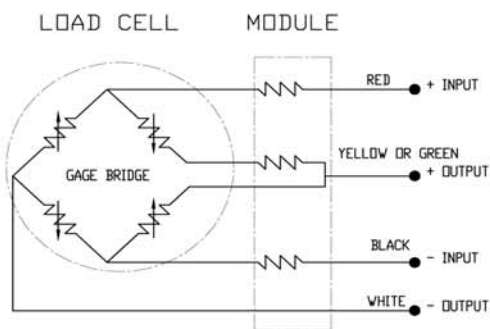

### High Level Amplified Output

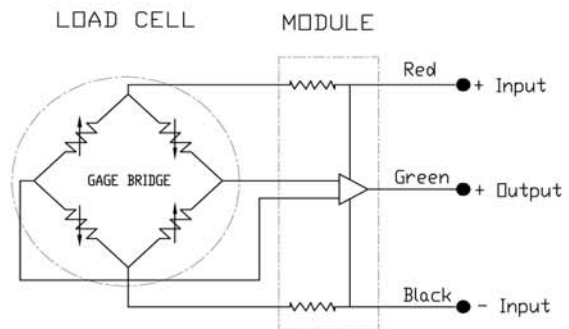

## options

**Standard Compensation Range:** +20 to +80°C

Z0: -40°C to +20°C

Z1: -20°C to +40°C

Z2: 0°C to +60°C

Z\*: Nonstandard compensation temp range

**Excitation Voltage (Bridge Output):** 5 Vdc Standard.

V00: Replace "00" with excitation between 1 and 10V. (At excitations less than 5V, sensitivity decreases proportionately.

Sensitivity at excitations > 5V equals 20 mV/V )

V2.5: Sensitivity equals 50 mV FSO nominal

V10: Sensitivity equals 100 mV FSO. Note that input impedance may increase substantially when excitations > 5 Vdc are specified.

**Excitation Voltage (Amplified):** 5 Vdc Standard (Higher excitations available: Consult factory)

**Standard Cable Length** = 5 ft (1.5 m)

L00F: Replace "00" with total cable length in feet. Specified only on units with SAE threads and lbf range

L10F: Units provided with 10 ft total cable length. Specified only on units with SAE threads and lbf range

L00M: Replace "00" with total cable length in meters. Specified only on units with metric threads and N range

L6M: Units provided with 6 m total cable length. Specified only on units with metric threads and N range

L10M: Units provided with 10 m total cable length. Specified only on units with metric threads and N range

**MXXP:** MXXP Special Compensation Module Location: Replace XX with percentage of cable length

M10P: Module located at 10% of cable length +/-5%

M25P: Module located at 25% of cable length +/-5%

M50P: Module located at 50% of cable length +/-5%

M75P: Module located at 75% of cable length +/-5%

**C:** Microtech type male or equivalent (w/o mate)

**R:** RJ Telephone type male (w/o mate)

**AN:** Calibrate lbf range unit in Newtons

**AL:** Calibrate N range unit in lbf

**AC:** Alternate calibration: Units with studs are calibrated in Tension by default. Option AC provides compression calibration in addition to tension calibration.

**AMP:** Provides amplified, ratiometric output of 0.5-4.5 V in tension only. Amplified units with option AC for amplified operation in tension and compression: Zero trimmed to + 2.5 Vdc +/- 5% of 2 V +/- 3% span in tension and compression at 5 Vdc input.

ELECTROMAGNETIC COMPATIBILITY RESIDENTIAL, COMMERCIAL AND LIGHT INDUSTRY

## ordering information

	Family	Body	Thread Type	Range	Multiplier	Units	Options																					
Example:	ELPF	T3	E	500		N	/option1/option2/...optionX																					
		T1, T2, T3 Ref Note*	M-Metric E-SAE	<table border="1"> <thead> <tr> <th>lbf</th> <th>N</th> <th>Body Style</th> </tr> </thead> <tbody> <tr><td>10</td><td>50</td><td>T1</td></tr> <tr><td>20</td><td>100</td><td>T2</td></tr> <tr><td>50</td><td>250</td><td>T2</td></tr> <tr><td>100</td><td>500</td><td>T3</td></tr> <tr><td>200</td><td>1K</td><td>T3</td></tr> <tr><td>500</td><td>2.5K</td><td>T3</td></tr> </tbody> </table>	lbf	N	Body Style	10	50	T1	20	100	T2	50	250	T2	100	500	T3	200	1K	T3	500	2.5K	T3	K: For ranges >1000	L=lbf N=Newton	* See above
lbf	N	Body Style																										
10	50	T1																										
20	100	T2																										
50	250	T2																										
100	500	T3																										
200	1K	T3																										
500	2.5K	T3																										
<p>NOTE: Metric threaded units must have Newtons range specified.</p> <p>NOTE: SAE threaded units must have lbf range specified.</p> <p>NOTE: Metric threaded units must have cable lengths specified in meters</p> <p>NOTE: Nominal is defined as any value within the range of +50% to -30% of the stated value.</p> <p>NOTE: Typical values: 50% of units will be delivered with specifications greater than the typical value and 50% of units will be delivered with specifications less than the typical value stated.</p> <p>*NOTE: EXXXX: Special Factory Designation for custom components. No options need to be incorporated into the unit part numbers.</p> <p>SXXXX designation reserved for MEAS Spec European operations.</p>																												

### CONTATO

#### Endereço

Rua Sete de Setembro, 2671 - Centro  
13560-181 - São Carlos - SP - Brasil

#### Telefone

+ 55 (16) 3371-0112

#### Fax

+ 55 (16) 3372-7800

#### Internet

[www.metrolog.net](http://www.metrolog.net)  
[metrolog@metrolog.net](mailto:metrolog@metrolog.net)



Metrolog Controles de Medição