

# Model 52M30 Accelerometer

- Small Size
- Jacketed Cable
- Integral Cable Shield
- Aluminum Housing
- Silicon MEMS Technology
- High g Ranges



The **Model 52M30** accelerometer has an advanced piezoresistive MEMS sensing element which offers excellent dynamic range and stability. This unit features a full bridge output with an operating temperature range from -40 to 121°C. A slight amount of gas damping provides outstanding shock survivability and a flat amplitude response to 7kHz.

## FEATURES

- 2-10 Vdc Excitation
- Ranges to  $\pm 2000$  g's
- Measures static acceleration
- Over shock protection to  $\pm 5,000$  g's
- Transverse sensitivity <3%
- Weight <5 grams
- Output ratiometric to excitation
- Resonant frequency to 26,000 Hz
- Linearity  $\pm 1\%$

## APPLICATIONS

- Automotive crash testing
- High impact research
- Biomechanical studies
- Shock testing

## dimensions

(Dimensions in Inches)

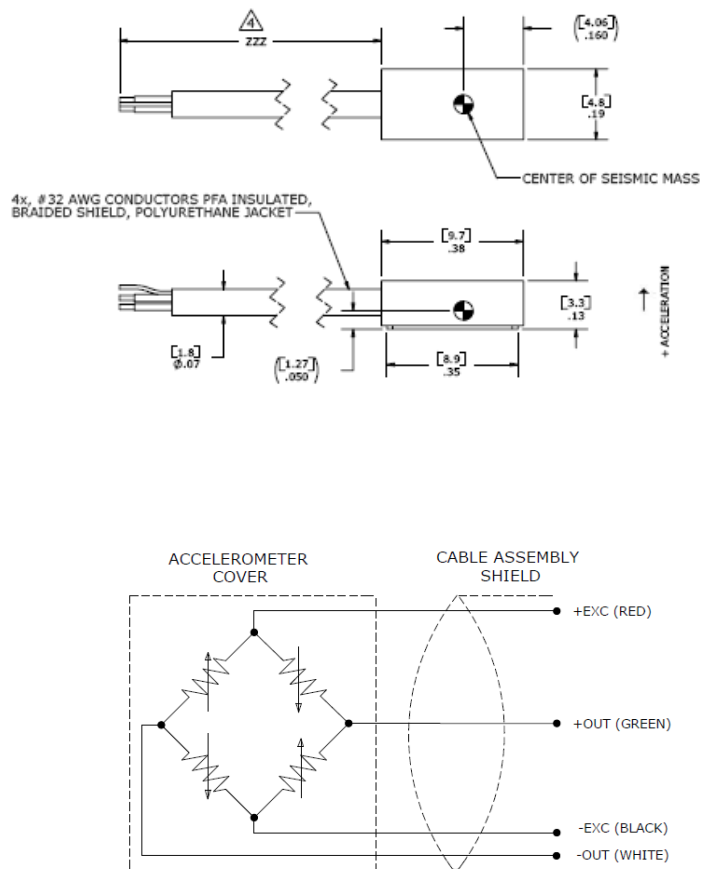

# Model 52M30 Accelerometer

## performance specifications

All values are typical at  $\pm 24^{\circ}\text{C}$ , 100 Hz and 10 Vdc excitation unless otherwise stated. Measurement Specialties reserves the right to update and change these specifications without notice. Standard product parameters are described in PSC-1004 for Plug & Play DC Accelerometers.

### Parameters

#### DYNAMIC

	$\pm 50$	$\pm 200$	$\pm 500$	$\pm 2000$	Notes
<b>Range(g)</b>	2	0.9	0.4	0.15	
Sensitivity (mV/g)	2	0.9	0.4	0.15	
Frequency Response (Hz)	0-400	0-600	0-800	0-2000	$\pm 2\%$
	0-1000	0-1400	0-2000	0-5000	$\pm 5\%$
	0-1400	0-1900	0-2800	0-7000	$\pm 1\text{dB}\%$
Resonance (Hz)	4000	8000	15000	26000	
Shock Limit (g)			5000		
Non-Linearity (% FSO)			$\pm 1$		
Transverse Sensitivity (%)			$< 3$		
Zero Acceleration Output (mV)			$< \pm 50$		
Thermal Zero Shift (%FSO/ $^{\circ}\text{C}$ (%FSO/ $^{\circ}\text{F}$ ))*			$\pm 0.2(\pm 0.11)$		
Thermal Sensitivity Shift (%/ $^{\circ}\text{C}$ (%/ $^{\circ}\text{F}$ ))*			$\pm 0.4(\pm 0.22)$		

#### ELECTRICAL

Excitation (Vdc)	2 to 10
Input Resistance ( $\Omega$ )	2400-5000
Output Resistance ( $\Omega$ )	2400-5000
Insulation Resistance (M $\Omega$ )	$> 100$

#### PHYSICAL

Case Material	Aluminum	Black anodized
Cable	32 AWG	PVC insulated
Weight (grams)	0.5	Without cable
Mounting	Adhesive	

#### ENVIRONMENTAL

Operating Temperature ( $^{\circ}\text{C}$ )	-40 to +121	
Humidity	Epoxy Sealed, IP61	Epoxy Sealed

#### PART NUMBERING

Model Number + Range (g's)+Cable Length (Options require factory-specified Model Numbers)

\*  $0^{\circ}\text{C}$  to  $+50^{\circ}\text{C}$  ( $32^{\circ}\text{F}$  to  $122^{\circ}\text{F}$ )

**Wiring color code:** +EXC = Red, -EXC = Black, +OUT = Green, -OUT = White

**Calibration supplied:** CS-FREQ-0100 NIST Traceable Amplitude Calibration from 20Hz to  $\pm 1\text{dB}$  Frequency Response Limit

**Optional accessories:** 101 Three Channel DC Signal Conditioner Amplifier

The information in this sheet has been carefully reviewed and is believed to be accurate; however, no responsibility is assumed for inaccuracies. Furthermore, this information does not convey to the purchaser of such devices any license under the patent rights to the manufacturer. Measurement Specialties, Inc. reserves the right to make changes without further notice to any product herein. Measurement Specialties, Inc. makes no warranty, representation or guarantee regarding the suitability of its product for any particular purpose, nor does Measurement Specialties, Inc. assume any liability arising out of the application or use of any product or circuit and specifically disclaims any and all liability, including without limitation consequential or incidental damages. Typical parameters can and do vary in different applications. All operating parameters must be validated for each customer application by customer's technical experts. Measurement Specialties, Inc. does not convey any license under its patent rights nor the rights of others.

## ordering info

PART NUMBERING Model Number+Range+Cable Length

52M30-ZZZZ-ZZZ

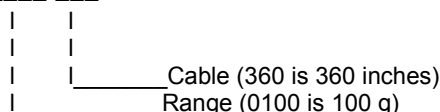

Example: 52M30-0500-360

Model 52M30, 500g Full Scale Range, 360 inches cable

### CONTATO

#### Endereço

Rua Sete de Setembro, 2671 - Centro  
13560-181 - São Carlos - SP - Brasil

#### Telefone

+ 55 (16) 3371-0112

#### Fax

+ 55 (16) 3372-7800

#### Internet

[www.metrolog.net](http://www.metrolog.net)  
[metrolog@metrolog.net](mailto:metrolog@metrolog.net)



Metrolog Controles de Medição