

Model EGCS-A2/B2 Accelerometer

Miniature Design
DC Response
10,000 g Over Range Stops
High Sensitivity

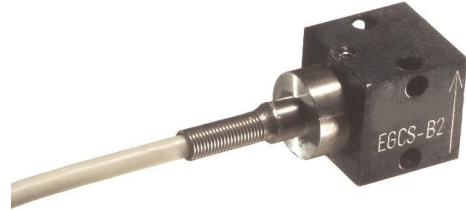

The Model EGCS accelerometers combine a damping ratio of 0.7 (Nominal) with built-in overrange stops that are set to protect the unit against 10,000g shocks. This is ideal for applications which may experience rough handling or in situations where the accelerometer must survive a high initial overload in order to make a low g measurement. These units feature a Wheatstone Bridge output with compensated temperature range of 20 to 80 °C.

FEATURES

- Compact
- Heavy Duty
- Static and Dynamic Measurement
- Frequency Response through 4000 Hz
- ± 1% Non-Linearity
- -40°C to +120°C Operating Temperature Range
- 10,000 g Overrange Protection

APPLICATIONS

- Blast Testing
- Machine Control
- Downhole
- Engine Testing

dimensions

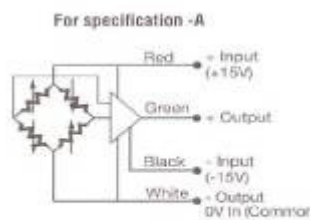
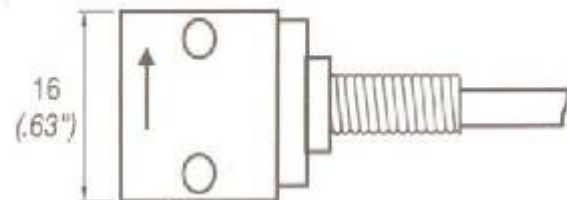
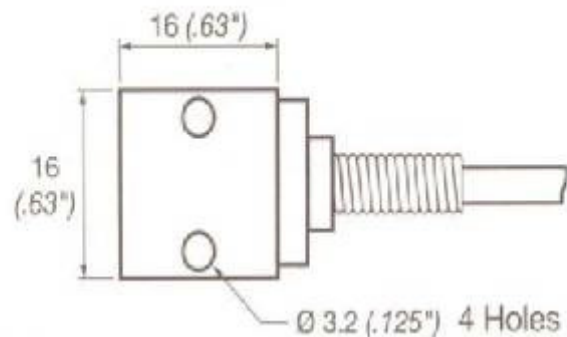

It is recommended that "0V COMMON" of the power supply be grounded if consistent with proper operation of the instrumentation system.

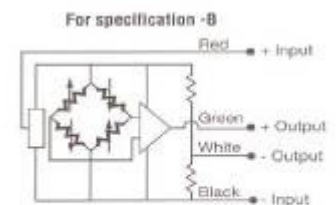

Common mode output voltage of +5V nom. referred to -Input

Model EGCS-A2/B2 Accelerometer

performance specifications

All values are typical at 24 °C and at ±15/28 Vdc excitation unless otherwise stated. Measurement Specialties, Inc. reserves the right to update and change these specifications without notice. Standard product parameters are described in PSC-1004 for Plug & Play DC

DYNAMIC

Range (±g)	5	10	25	50	100	250	500	1000	2500	5000
Sensitivity (mV/g) A2/B2	1000/500	500/250	200/100	100/50	50/25	20/10	10/5	5/2.5	2/1	1/0.5
Min. Freq. Response (Hz)	80	120	240	350	500	750	1000	1500	2000	2400
Nom. Resonance (Hz)	300	400	800	1200	1800	2600	3500	5000	7000	8000
Non-Linearity (%)					±1					
Transverse Sensitivity (% MAX)					2					
Zero Acceleration Output (mV)					±250					
Thermal Zero Shift					±50mV/50 °C (100 °F)					
Thermal Sensitivity Shift					±2.5%/50 °C (100 °F)					
Damping Ratio (Nominal)					0.7					

ELECTRICAL

Voltage Excitation (Vdc)	A2: ±15 B2: 28 (24/32)
Input Resistance (mA)	15 (typical)
Output Resistance (Ohms)	1K (typical)

PHYSICAL

Case Material	Stainless Steel
Cable Connections (meter)	1
Weight (DO/D1S)	10/12 grams
Mounting (DO/D1S)	Screw/Stud

ENVIRONMENTAL

Shock Limit Sensitive Axis (g)	±500	±1000	±2000	±5000	±10000
Operating Temperature (°C)	-40 to 120				
Compensated Temperature (°C)	20 to 80				

The information in this sheet has been carefully reviewed and is believed to be accurate; however, no responsibility is assumed for inaccuracies. Furthermore, this information does not convey to the purchaser of such devices any license under the patent rights to the manufacturer. Measurement Specialties, Inc. reserves the right to make changes without further notice to any product herein. Measurement Specialties, Inc. makes no warranty, representation or guarantee regarding the suitability of its product for any particular purpose, nor does Measurement Specialties, Inc. assume any liability arising out of the application or use of any product or circuit and specifically disclaims any and all liability, including without limitation consequential or incidental damages. Typical parameters can and do vary in different applications. All operating parameters must be validated for each customer application by customer's technical experts. Measurement Specialties, Inc. does not convey any license under its patent rights nor the rights of others.

ordering info

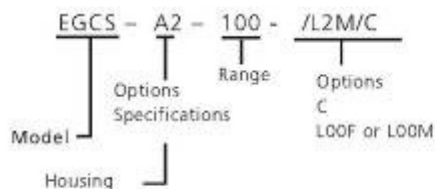

COMPENSATED TEMPERATURE RANGES:	STANDARD Z*	= 20°C to 80°C (70°F to 170°F) = Non-standard, contact factory
EXCITATION VOLTAGE:	STANDARD V*	= (A2) +/-15VDC; (B2) 28 VDC = Non-standard Excitation with standard FSO and non-standard TSS, contact factory.
SPECIAL LEAD LENGTH:	LOOF LOOM	= Replace "00" with total length in feet. = Replace "00" with total length in meters.
CONNECTOR WIRED TO CABLE:	C	= Microtech type male or equivalent.

CONTATO

Endereço

Rua Sete de Setembro, 2671 - Centro
13560-181 - São Carlos - SP - Brasil

Telefone

+ 55 (16) 3371-0112

Fax

+ 55 (16) 3372-7800

Internet

www.metrolog.net
metrolog@metrolog.net



Metrolog Controles de Medição