

# Model 3022 Accelerometer



Piezoresistive MEMS  
DC Response  
Circuit Board Mountable  
Low Cost

The **Model 3022** is a silicon MEMS accelerometer in a Wheatstone bridge configuration. The accelerometer is packaged on a ceramic substrate with an epoxy sealed ceramic cover and is designed for adhesive mounting. The accelerometer is offered in ranges from  $\pm 2g$  to  $\pm 200g$  range and provides a flat frequency response to minimum 2000Hz. The silicon MEMS sensor is gas damped and incorporates over-range stops for high-g shock protection.

For a similar accelerometer designed for bolt mounting, see the model 3028.

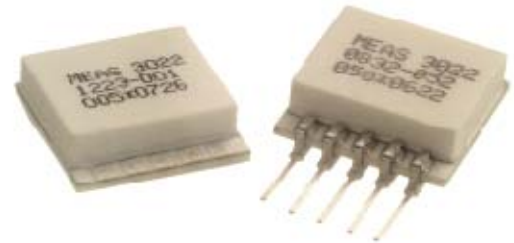

## dimensions

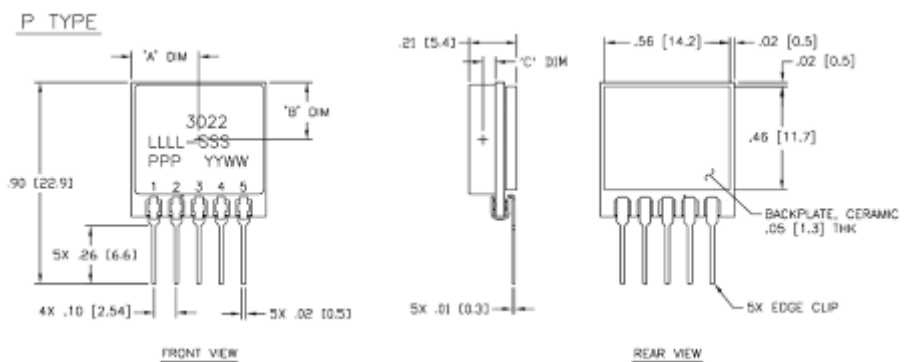
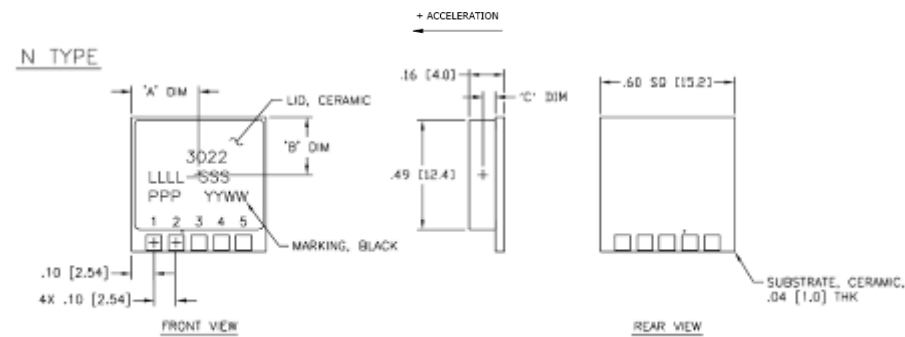

## FEATURES

- Adhesive Mounted
- $\pm 0.5\%$  Non-linearity
- Open Wheatstone Bridge
- DC Response
- Gas Damping
- Built-in Overrange Stops
- Low Power Consumption

## APPLICATIONS

- Vibration & Shock Monitoring
- Motion Control
- Impact & Shock Testing
- Modal Analysis
- Embedded Applications
- Machinery

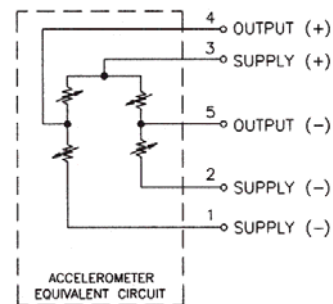

# Model 3022 Accelerometer

## performance specifications

All values are typical at +24°C, 100Hz and 5Vdc excitation unless otherwise stated. Measurement Specialties reserves the right to update and change these specifications without notice. Standard product parameters are described in PSC-1002 for Embedded DC Accelerometers.

### Parameters

#### DYNAMIC

	±2	±5	±10	±20	±50	±100	±200	Notes
Range (g)								
Sensitivity (mV/g) <sup>1</sup>	8.0-20.0	6.0-15.0	3.0-6.0	1.5-3.0	0.6-1.5	0.3-0.6	0.15-0.3	@5Vdc Excitation ±5%
Frequency Response (Hz)	0-150	0-250	0-400	0-600	0-1000	0-1500	0-2000	
Natural Frequency (Hz)	700	800	1000	1500	4000	6000	8000	
Non-Linearity (%FSO)	±0.5	±0.5	±0.5	±0.5	±0.5	±0.5	±0.5	
Transverse Sensitivity (%)	3	3	3	3	3	3	3	
Damping Ratio	0.7	0.7	0.7	0.7	0.7	0.7	0.6	
Shock Limit (g)	5000	5000	5000	5000	5000	5000	5000	

#### ELECTRICAL

Zero Acceleration Output (mV)	±25	±25	±25	±25	±25	±25	±25	Differential
Excitation Voltage (Vdc)	2 to 10	2 to 10	2 to 10	2 to 10	2 to 10	2 to 10	2 to 10	
Input Resistance (Ω)	2500- 6500	2500- 6500	2500- 6500	2500- 6500	2500- 6500	2500- 6500	2500- 6500	
Output Resistance (Ω)	2500- 6500	2500- 6500	2500- 6500	2500- 6500	2500- 6500	2500- 6500	2500- 6500	
Insulation Resistance (MΩ)	>100	>100	>100	>100	>100	>100	>100	@50Vdc Maximum
Residual Noise (µV RMS)	10	10	10	10	10	10	10	
Ground Isolation	Isolated from Mounting Surface							

#### ENVIRONMENTAL

Thermal Zero Shift (%FSO/°C)	-0.09	-0.09	-0.09	-0.09	-0.09	-0.09	-0.09	Typical
Thermal Sensitivity Shift (%/°C)	-0.15	-0.15	-0.15	-0.15	-0.15	-0.15	-0.15	Typical
Operating Temperature (°C)	-40 to +125							
Compensated Temperature (°C)	Not Compensated							See Note 2
Storage Temperature (°C)	-40 to +125							

#### PHYSICAL

Case Material	Ceramic
Weight (grams)	3.1
Mounting	Adhesive or solder

<sup>1</sup> Output is ratiometric to excitation voltage

<sup>2</sup> Order model 3022-XXX-10254 for temperature compensation resistor values included in the calibration certificate.

The information in this sheet has been carefully reviewed and is believed to be accurate; however, no responsibility is assumed for inaccuracies. Furthermore, this information does not convey to the purchaser of such devices any license under the patent rights to the manufacturer. Measurement Specialties, Inc. reserves the right to make changes without further notice to any product herein. Measurement Specialties, Inc. makes no warranty, representation or guarantee regarding the suitability of its product for any particular purpose, nor does Measurement Specialties, Inc. assume any liability arising out of the application or use of any product or circuit and specifically disclaims any and all liability, including without limitation consequential or incidental damages. Typical parameters can and do vary in different applications. All operating parameters must be validated for each customer application by customer's technical experts. Measurement Specialties, Inc. does not convey any license under its patent rights nor the rights of others.

## ordering info

PART NUMBERING Model Number+Range+Electrical Connection

3022-GGG-P

| |  
 | | Electrical Connection (P=pins, N=solder pads)  
 | Range (010 is 10g)

Example: 3022-010-P  
Model 3022, 10g, Pins

### CONTATO

#### Endereço

Rua Sete de Setembro, 2671 - Centro  
13560-181 - São Carlos - SP - Brasil

#### Telefone

+ 55 (16) 3371-0112

#### Fax

+ 55 (16) 3372-7800

#### Internet

[www.metrolog.net](http://www.metrolog.net)  
[metrolog@metrolog.net](mailto:metrolog@metrolog.net)



Metrolog Controles de Medição